

Island Multi-Deck **Hot & Cold** Packaged Food Merchandiser

IP #HCI8172-SC
83" L x 74-1/8" D x 72"H

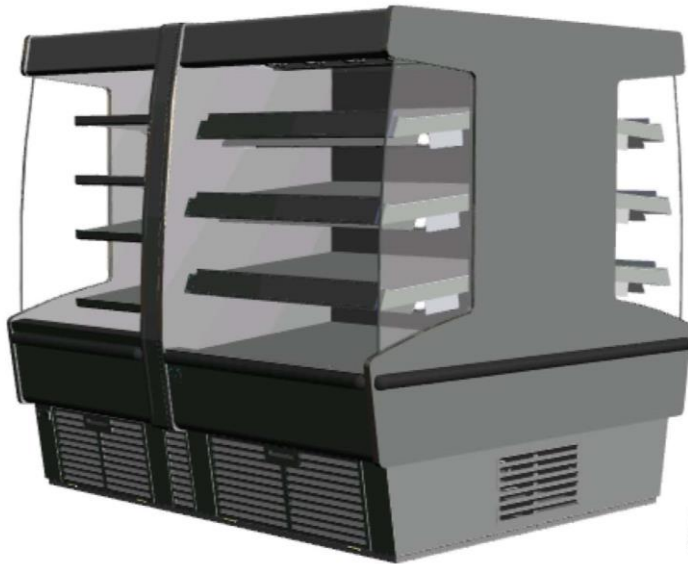

COLD SIDE

HOT SIDE

*Scroll down –
following pages
have additional
information*

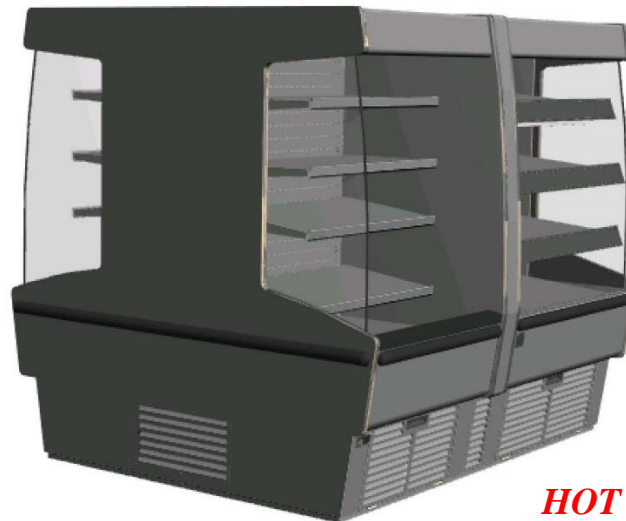

COLD SIDE

**HOT
SIDE**

Approval – Complete All Sections

Colors:

Body: _____

Bumper: _____

Refrigeration: Self Contained

Electric:

Voltage: 120/208V

Phase: Three

Source: Floor

Delivery

Site: Loading Dock ___ Ground Level ___

Delivery hours: _____

Depth of case is 74" which will fit through narrowest space between delivery point and install location **Yes ___ No ___ If no – CALL US ASAP**

Approval signature: _____

Date: _____

See last page for specifications table – your signature above verifies the installation site has the required power as shown

**Celebrating 70
Years in 2017!**



Atlantic Food Bars
Hot & Cold Food
Merchandising Equipment
Specialists

888-MEAL-SOLUTIONS
(888-632-5765)
www.atlanticfoodbars.com

Island Multi-Deck **Hot & Cold** Packaged Food Merchandiser

IP #HCI8172-SC
83" L x 74-1/8" D x 72"H

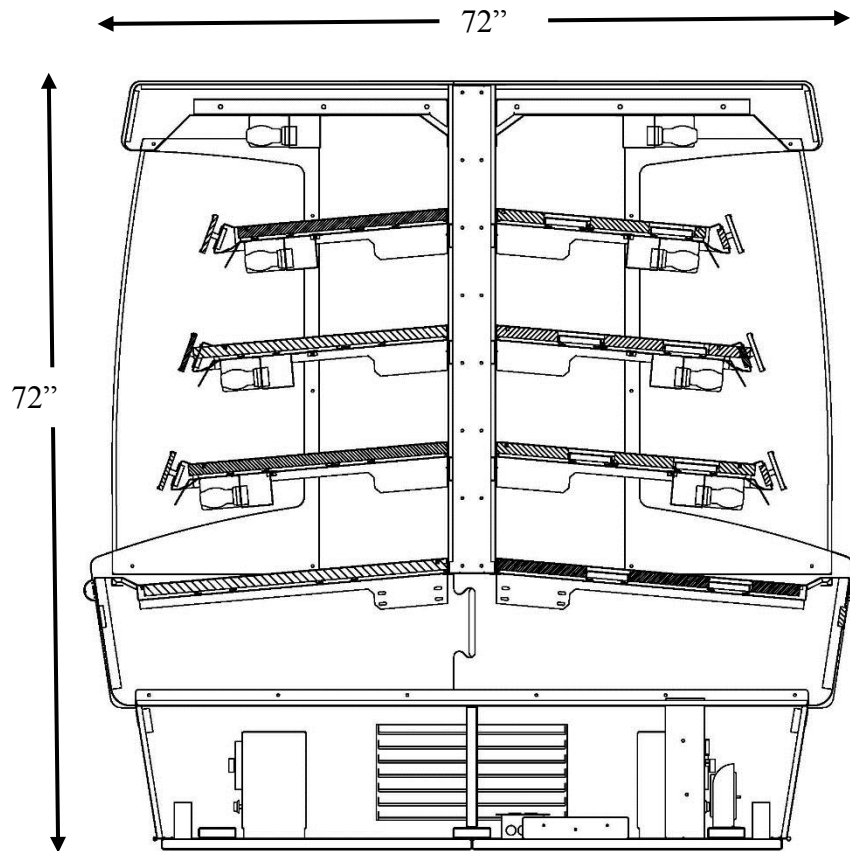

Cross Section - Hot

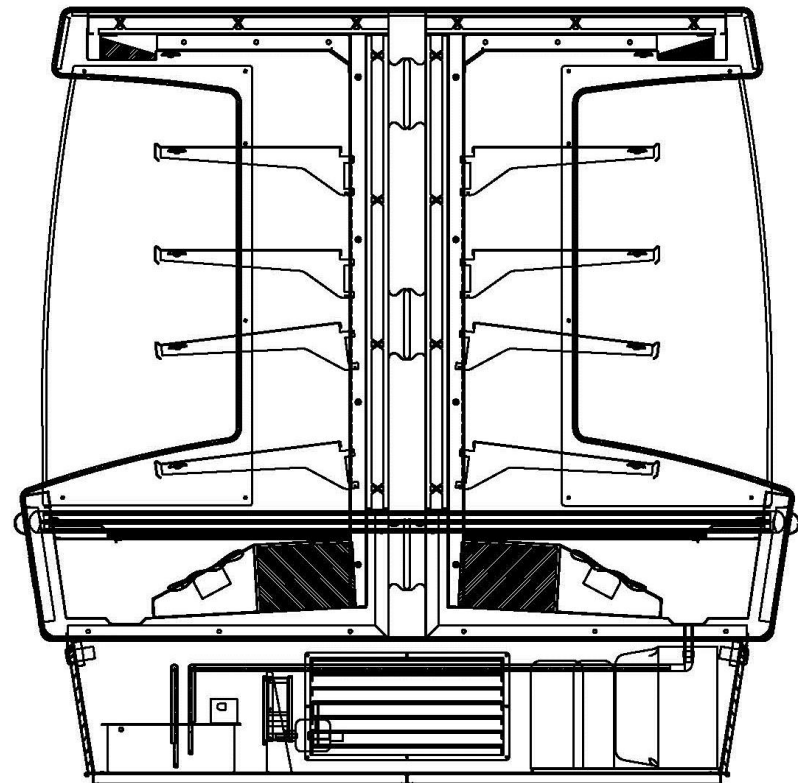

Cross Section - Cold



Atlantic Food Bars
Hot & Cold Food
Merchandising Equipment
Specialists

Scroll down – following page has additional information

888-MEAL-SOLUTIONS
(888-632-5765)
www.atlanticfoodbars.com

Island Multi-Deck **Hot & Cold** Packaged Food Merchandiser

IP #HCI8172-SC
83" L x 74-1/8" D x 72" H

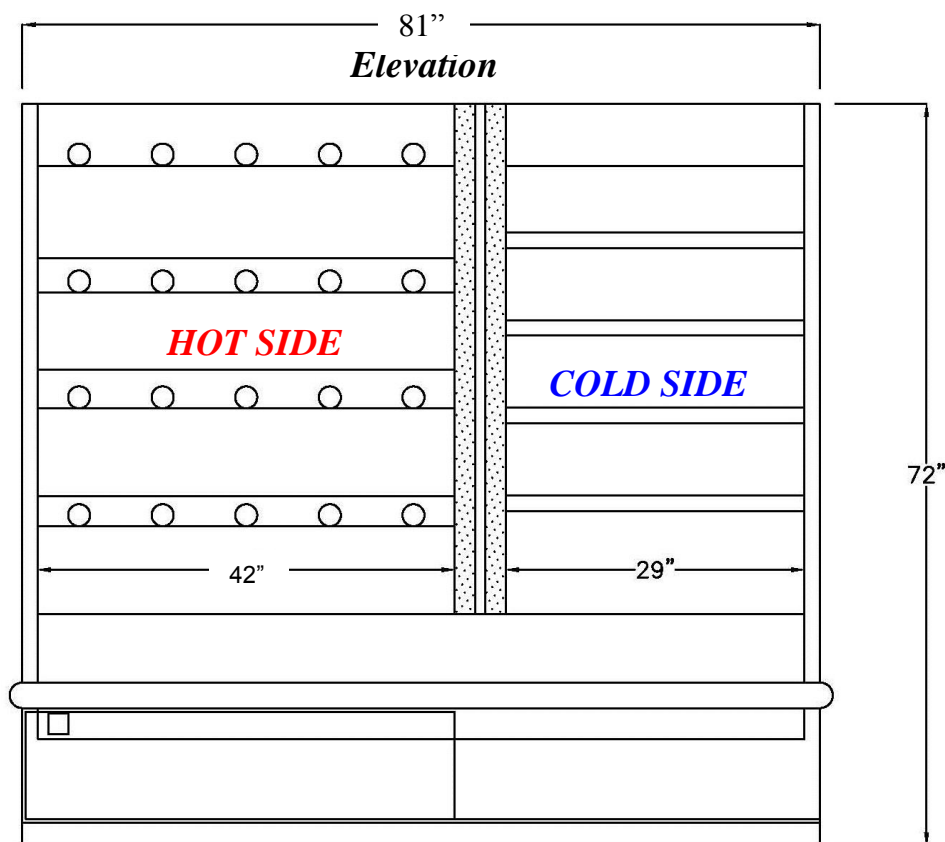
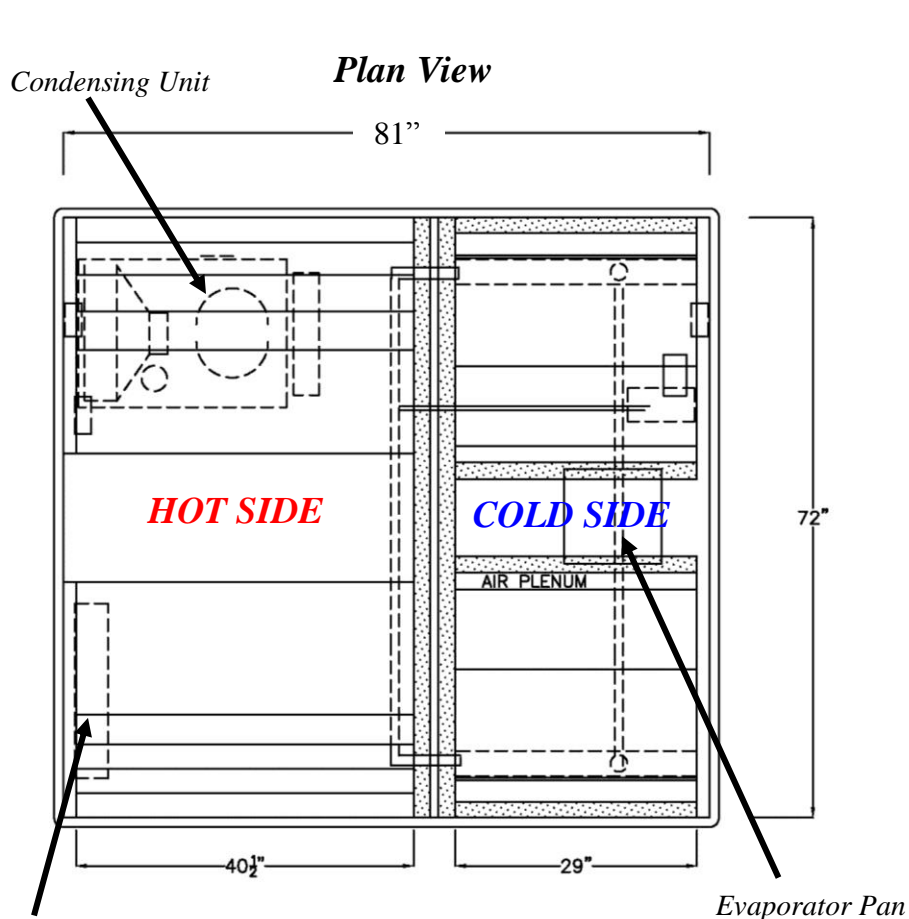

Internal Part #	Custom Description	Dimensions	Voltage	Self-contained Refrigeration
				Amps 3 Ph
HCI8172-SC	6'-8" Island Multi-Deck Hot & Cold Packaged Food Merchandiser	83" L x 74" D x 72" H	120/208	55



Atlantic Food Bars
Hot & Cold Food
Merchandising Equipment
Specialists

888-MEAL-SOLUTIONS (888-632-5765)
www.atlanticfoodbars.com