

Nantucket™

**12' Self-Service Two Tier Combination
Hot Food Merchandiser**

IP #NAN14436-BP3-SRM
12'-0" L x 37" D x 67" H

Details per sign off and specifications on
page 2

Approval signature: _____

Date: _____

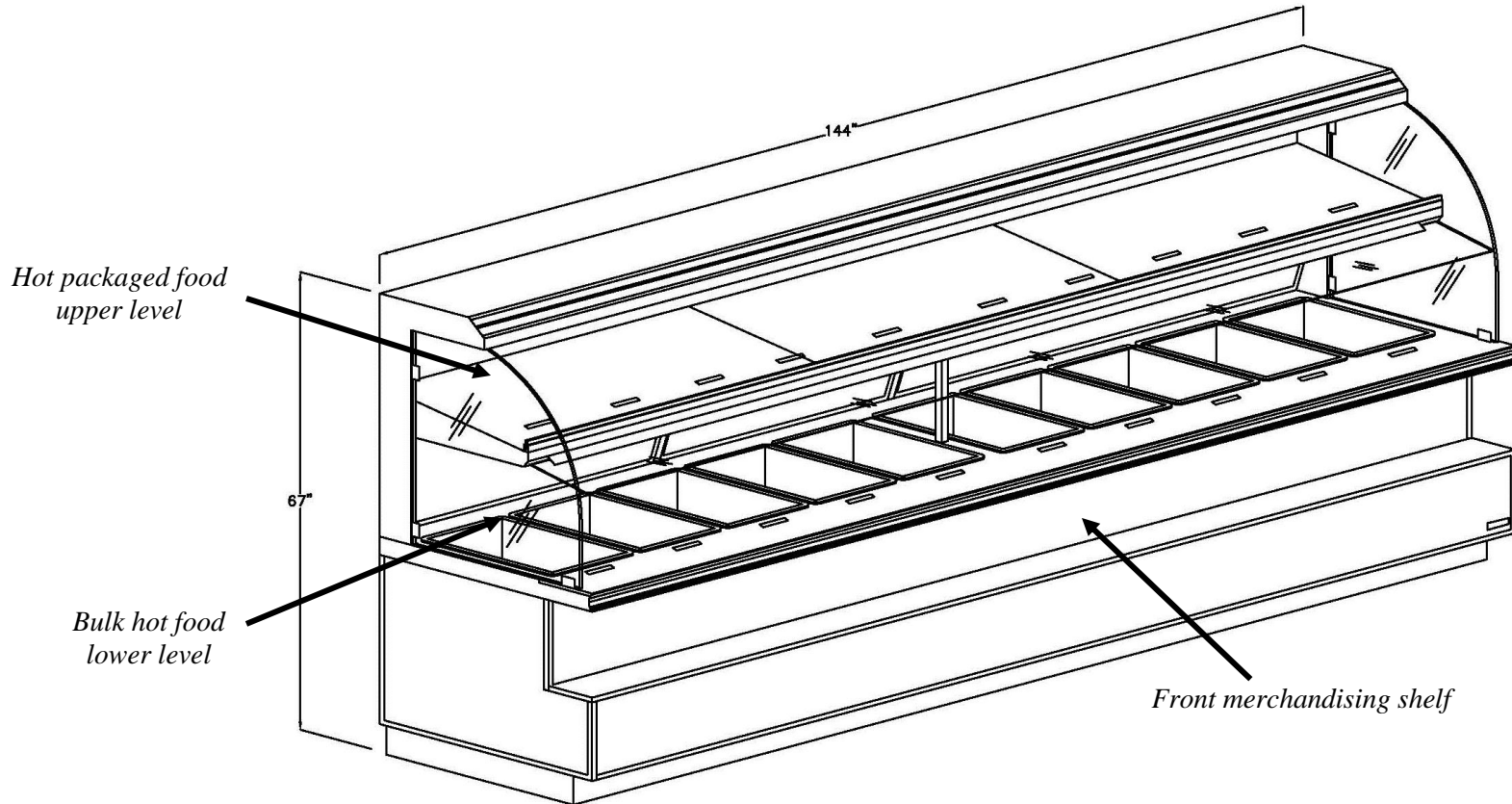

Plan View

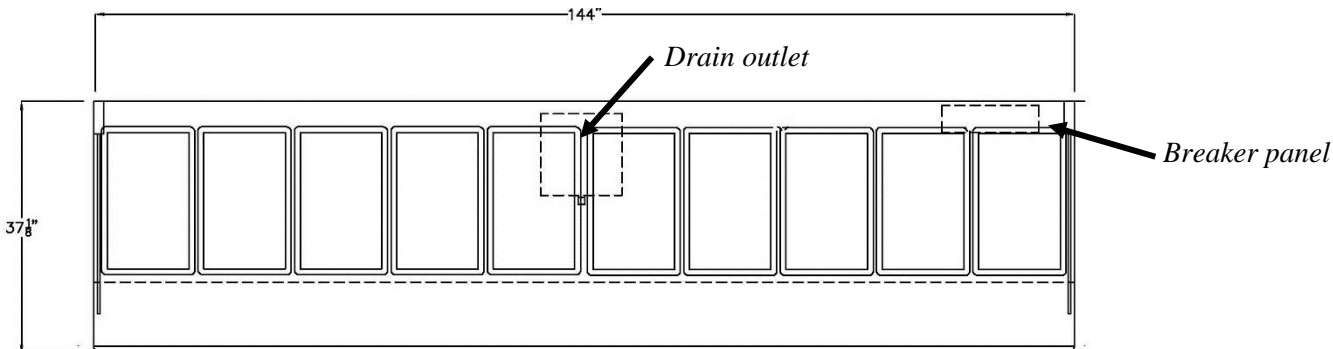

Scroll down for more views

Atlantic Food Bars
Hot Food Merchandising
Equipment Specialists

888-MEAL-SOLUTIONS (888-632-5765)
www.atlanticfoodbars.com

Nantucket™

12' Self-Service Two Tier Combination Hot Food Merchandiser

IP #NAN14436-BP3-SRM

12'-0" L x 37" D x 67" H

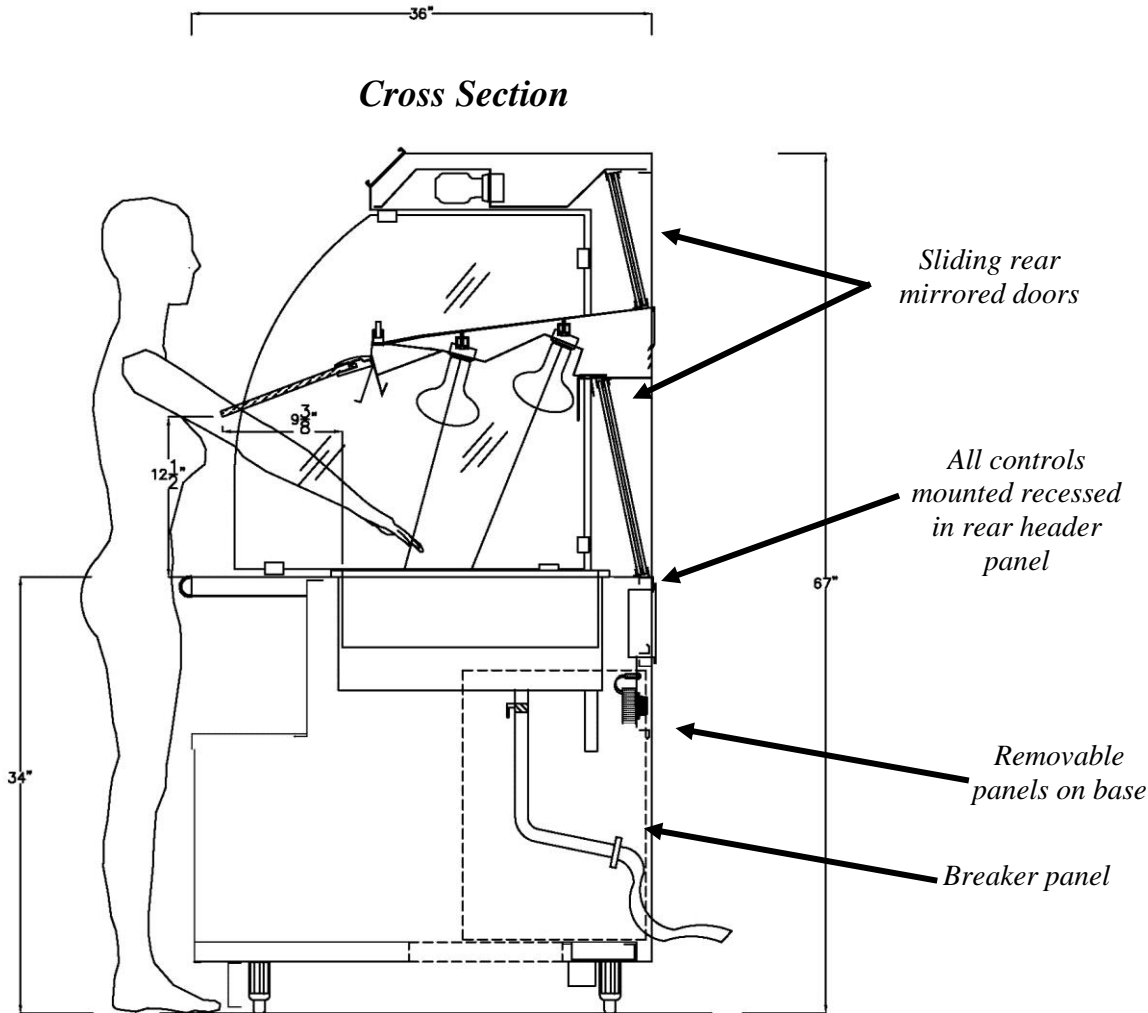

Approval – Complete All Sections

Colors:

Body: Stainless Steel

Bumper: _____

Countertop: Stainless Steel

Electric:

Voltage 120/208V

Phase: Three

Source: Floor

Delivery

Site: Loading Dock ___ Ground Level ___

Delivery hours: _____

Depth of case is 37" which will fit through narrowest space between delivery point and install location. Yes ___ No ___ If no – CALL US ASAP

Approval signature: _____

Date: _____

See last page for specifications table – your signature above verifies the installation site has the required power as shown

Internal Part #	Custom Description	Dimensions	Voltage	Amps 3 Ph	Chicken Capacity	12" x 20" Pan Openings
NAN14436-BP3-SRM	12' Two Tier Combination Hot Food Merchandiser	12'-0" L x 37" D x 67" H	120/208	53.0	36	10

Requires 70-amp circuit



888-MEAL-SOLUTIONS (888-632-5765)

www.atlanticfoodbars.com