

Full Service Refrigerated Fresh Seafood Merchandiser

With Air Overflow Refrigeration System
IP# FSC12256-BH3-CWPDL-DPS-KKV-SS
IP# FSCN10735-DPS-W2

Details per sign off on page 4 and specifications on page 3

Approval signature: _____

Date: _____

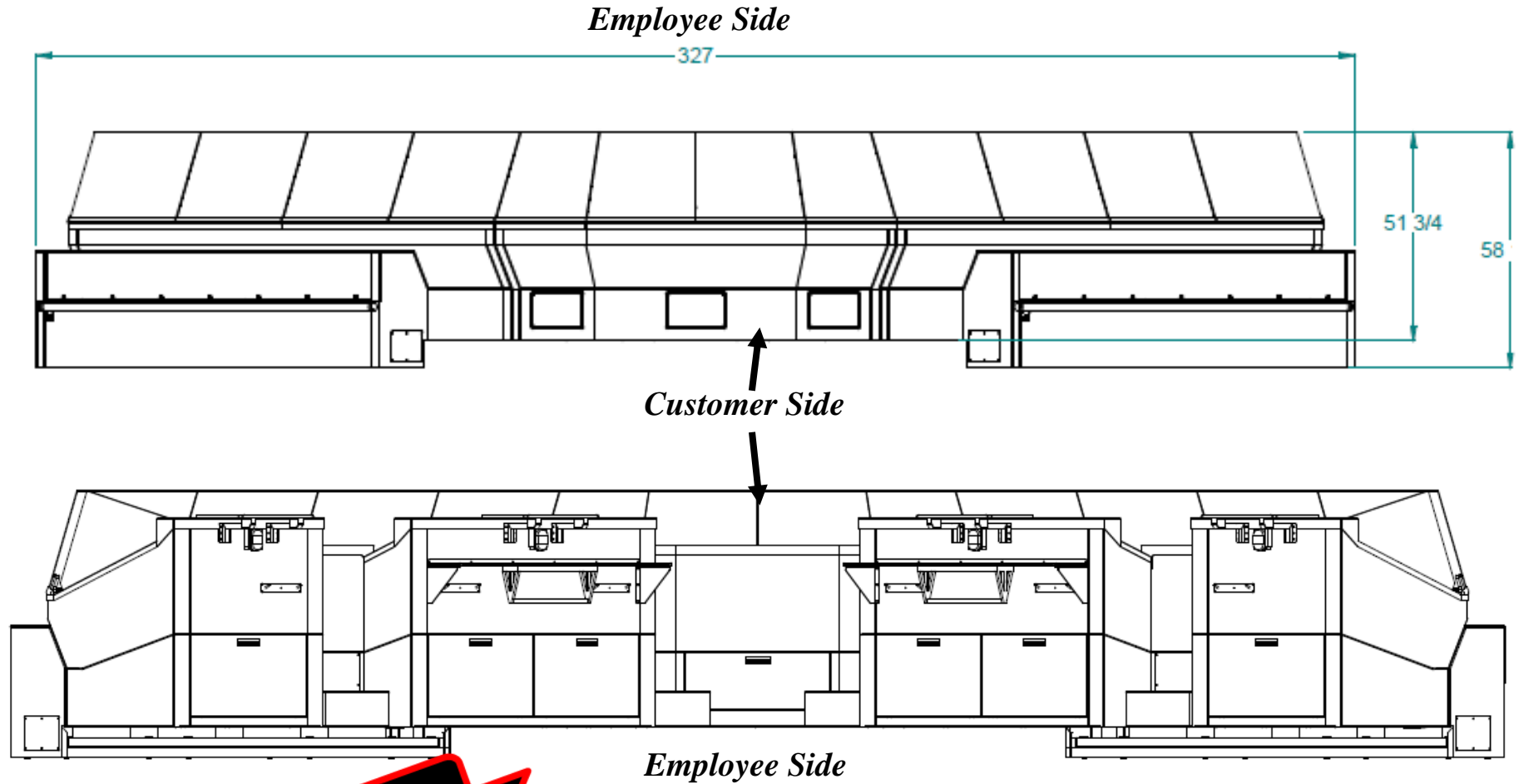

**Celebrating 70
Years in 2017!**



SEA
Atlantic Food Bars
Seafood Merchandising
Equipment Specialists

Scroll down for more views

888-MEAL-SOLUTIONS
(888-632-5765)
www.atlanticfoodbars.com

Full Service Refrigerated Fresh Seafood Merchandiser

With Air Overflow Refrigeration System

IP# FSC12256-BH3-CWPD-L-DPS-KKV-SS

122" L x 71½" D x 45¾" H

IP# FSCN10735-DPS-W2

107" L x 35" D x 39 3/8" H

Details per sign off on page 4 and specifications on page 3

Approval signature: _____

Date: _____

Plan View

Employee Side

Customer Side

Customer Side

Add GFI to this end panel of KKV section

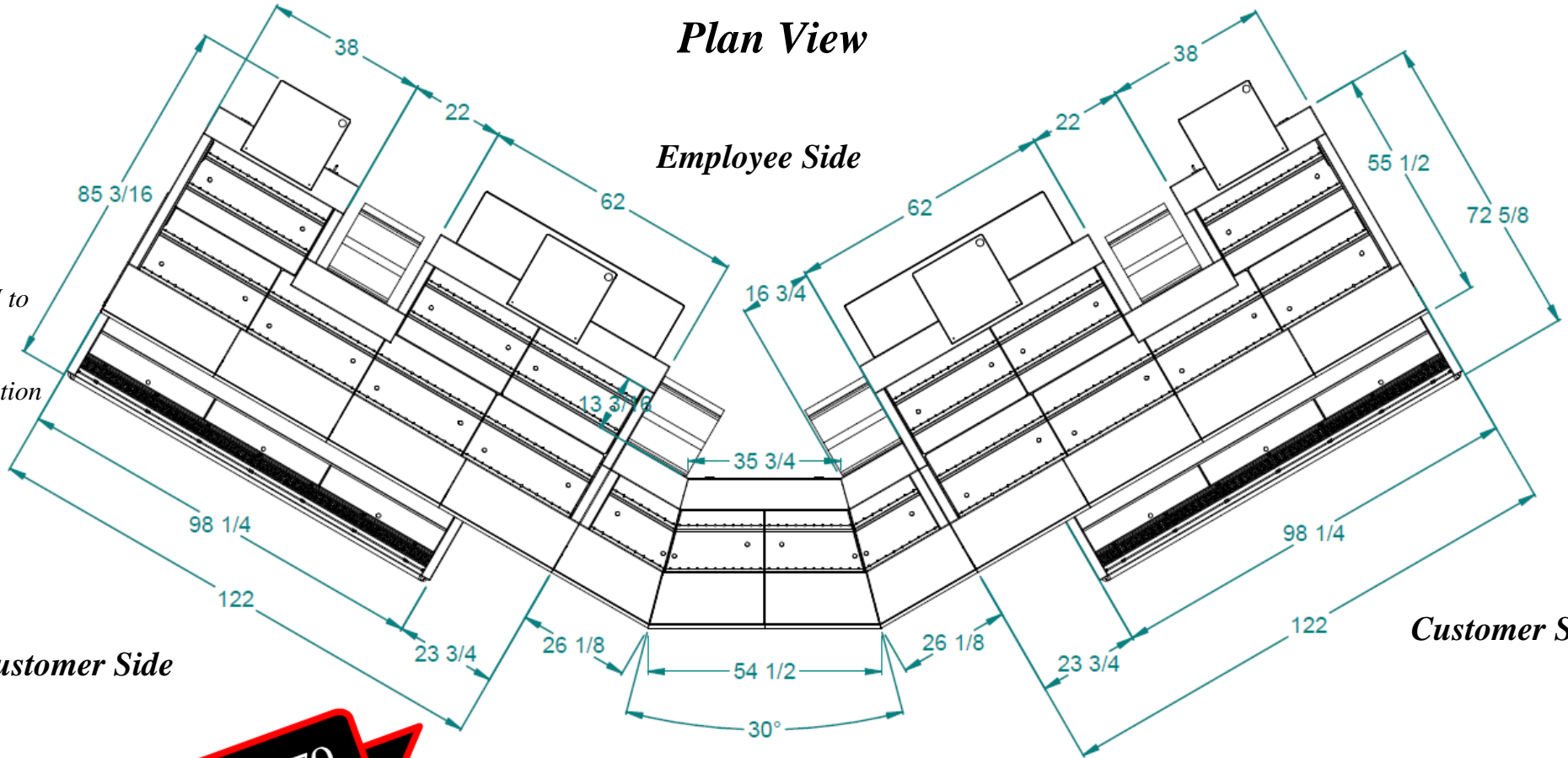

Scroll down for more views

Celebrating 70 Years in 2017!



Atlantic Food Bars
Seafood Merchandising
Equipment Specialists

888-MEAL-SOLUTIONS
(888-632-5765)
www.atlanticfoodbars.com

Full Service Refrigerated Fresh Seafood Merchandiser

With Air Overflow Refrigeration System
 IP# FSC12256-BH3-CWPD-L-DPS-KKV-SS

a 122" L x 71½" D x 45¾" H
 IP# FSCN10735-DPS-W2
 107" L x 35" D x 39 3/8" H

Cross Sections

Details per sign off on page 4 and specifications on this page

Approval signature: _____

Date: _____

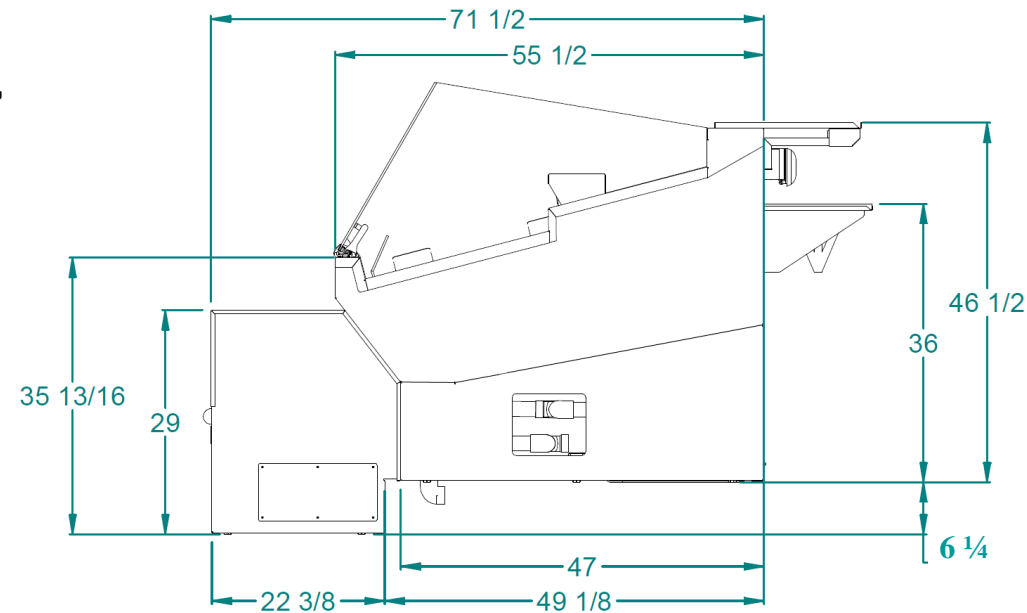
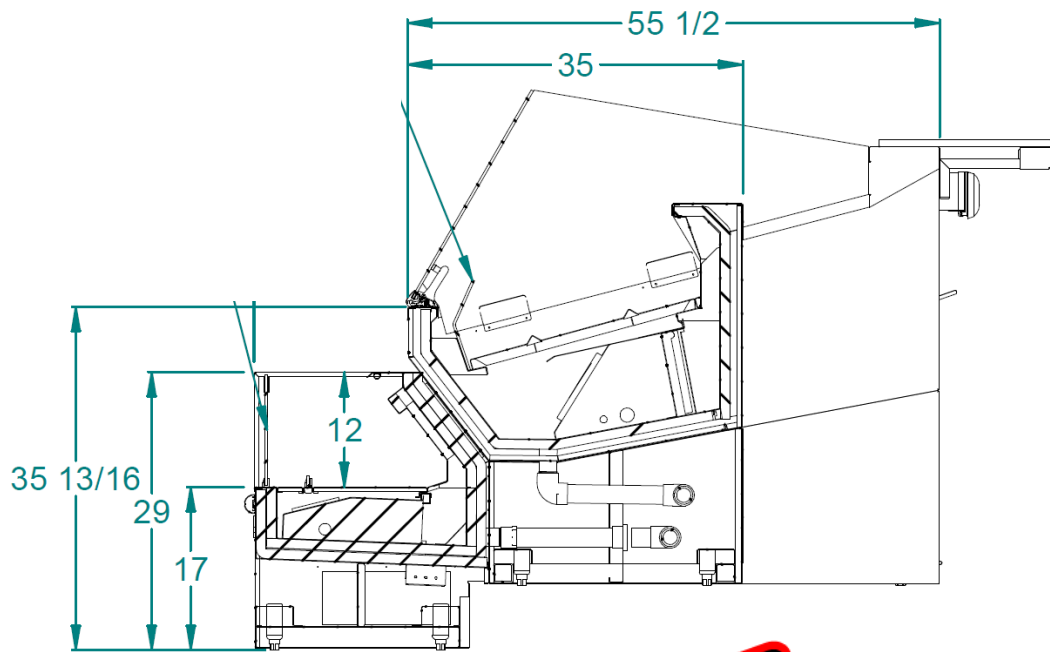

Scroll down for more views



Atlantic Food Bars
 Seafood Merchandising
 Equipment Specialists

888-MEAL-SOLUTIONS
 (888-632-5765)
www.atlanticfoodbars.com

Full Service Refrigerated Fresh Seafood Merchandiser

With Air Overflow Refrigeration System
 IP# FSC12256-BH3-CWPD-L-DPS-KKV-SS
 122" L x 71½" D x 45¾" H
 IP# FSCN10735-DPS-W2
 107" L x 35" D x 39 3/8" H

Approval – Complete All Sections

Colors:

Body: Stainless Steel
 Bumper: black

Refrigeration: Remote Refrigerant _____

Electric:

Voltage 120V
 Phase: Single

Delivery

Site: Loading Dock ____ Ground Level ____

Delivery hours: _____

Depth of deepest case is 73" which will fit through narrowest space between delivery point and install location. Yes ____ No ____ If no – CALL US ASAP

Approval signature: _____

Date: _____

See last page for specifications table – your signature above verifies the installation site has the required power as shown

Internal Part #	Custom Description	Dimensions	Voltage	Amps 1 Ph	Electrical	BTU
FSCN12256-BH3-CWPD-L-DPS-KKV-SS	10' Fresh Seafood Merchandiser with Refrigerated Bunker	10'-2" L x 71½" D x 45¾" H	120	43.0	2 each 120V 20 Amp circuits for scales; 1 each 120V 15 Amp circuits for fans/lights *	13,600
FSCN12256-BH3-CWPD-L-DPS-DR-KKV-SS *	10' Fresh Seafood Merchandiser with Refrigerated Bunker	10'-2" L x 71½" D x 45¾" H	120	59.0*	2 each 120V 20 Amp circuits for scales; 1 each 120V 20 Amp circuit for convenience outlet; 1 each 120V 15 Amp circuits for fans/lights *	13,600
FSCN10735-DPS-W2	9' Fresh Seafood Merchandiser	8'-11" L x 35" D x 39 3/8" H	120	3.0	1 ea 120V 15 Amp circuit for fans/lights	4,900

*case with convenience outlet on it. Suction temp = 20°

Celebrating 70 Years in 2017!



Atlantic Food Bars
 Seafood Merchandising
 Equipment Specialists

888-MEAL-SOLUTIONS (888-632-5765)
 www.atlanticfoodbars.com