

Make your Hot Grab & Go Food offerings a self service profit center with our RHP Series One & Two Level Round Hot Rotisserie Chicken Grab & Go Island Merchandiser



In a footprint as small as 36", you can increase your offering, create more impulse sales, and grow your hot food program. Based upon hourly and daily traffic patterns, you can utilize infinite temperature control for each individual hot deck to control shrink, maximizing your merchandising impact while continuing to maintain temperature.

This one or two level case is ideal, not just for rotisserie chicken, but for all packaged foods – turn off the heat on the lower level to merchandise dry goods. If you are selling hot food full service, you won't believe the profitability of this self service unit due to reduced labor costs, convenience for shoppers, higher sales and lower shrink.

This unit is a **MONEY MAKER** and a **SELL-THROUGH BEAST** !

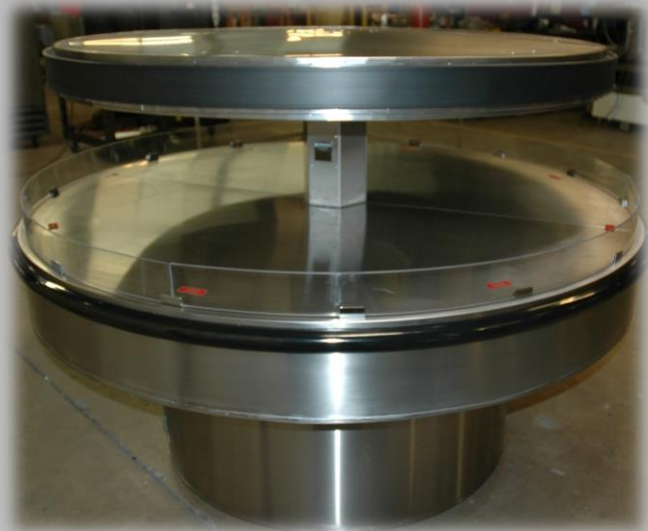

RHP Series

One & Two Level Round Hot Rotisserie Chicken Grab & Go Island Merchandiser



Atlantic Food Bars
Hot & Cold Food Equipment Specialists

888-MEAL-SOLUTIONS (888-632-5765)

info@atlanticfoodbars.com www.atlanticfoodbars.com



RHP Series

One & Two Level Round Hot Rotisserie Chicken Grab & Go Island Merchandiser

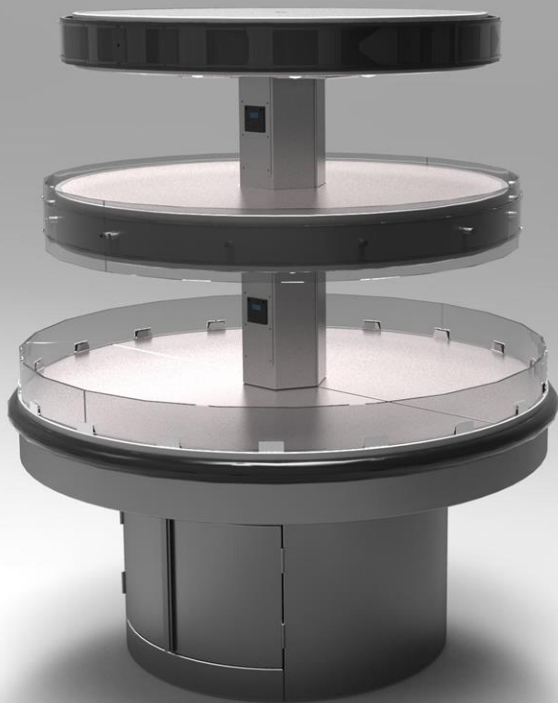

RHP4848T 4' Two-Level Model Shown

Standard Features

- ◆ Atlantic's exclusive top heat and light system provides full coverage heat, brilliant illumination and reduced maintenance costs
- ◆ The industry's most reliable and maintenance-free bottom heat system
- ◆ Infinite controls on bottom and top heat
- ◆ Flat, stainless steel decks are easy to clean
- ◆ Hidden controls in base
- ◆ Safety shields around deck protect children from hot deck
- ◆ Stainless steel body and heavy duty protective bumper in colors of your choice

RHP5555 5' Model Shown

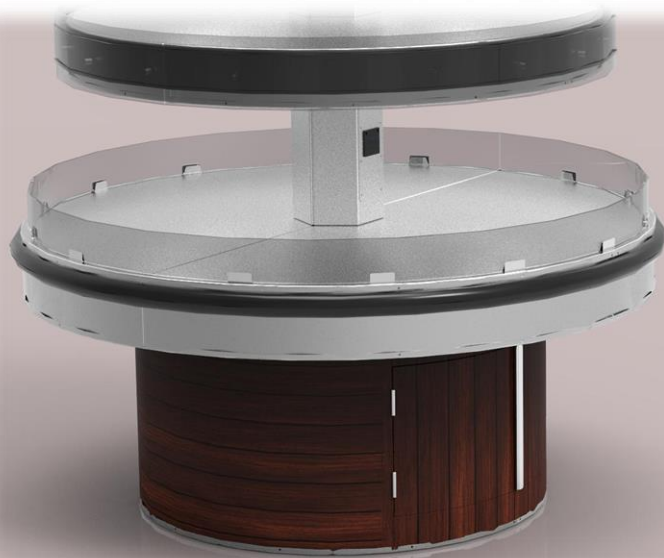

Options

- Additional merchandising deck – second level increases capacity and visual appeal – more cross merchandising opportunities
- Entire body to be powder coated steel in lieu of stainless steel



HOT
Atlantic Food Bars
Hot & Cold Food Equipment Specialists

888-MEAL-SOLUTIONS (888-632-5765)

info@atlanticfoodbars.com www.atlanticfoodbars.com



RHP Series

One Level Round Hot Rotisserie Chicken Grab & Go Island Merchandiser

Atlantic Food Bars RHP Series Three-Level Hot Food Grab & Go Merchandisers are covered by our INDUSTRY'S LONGEST WARRANTY – 2 year parts and labor. Warranty does not cover glass breakage or heat lamps, or abuse / misuse by operator. It is our company's policy and mission to continually improve our products, consequently, Atlantic Food Bars reserves the rights to change materials and specifications without notice.

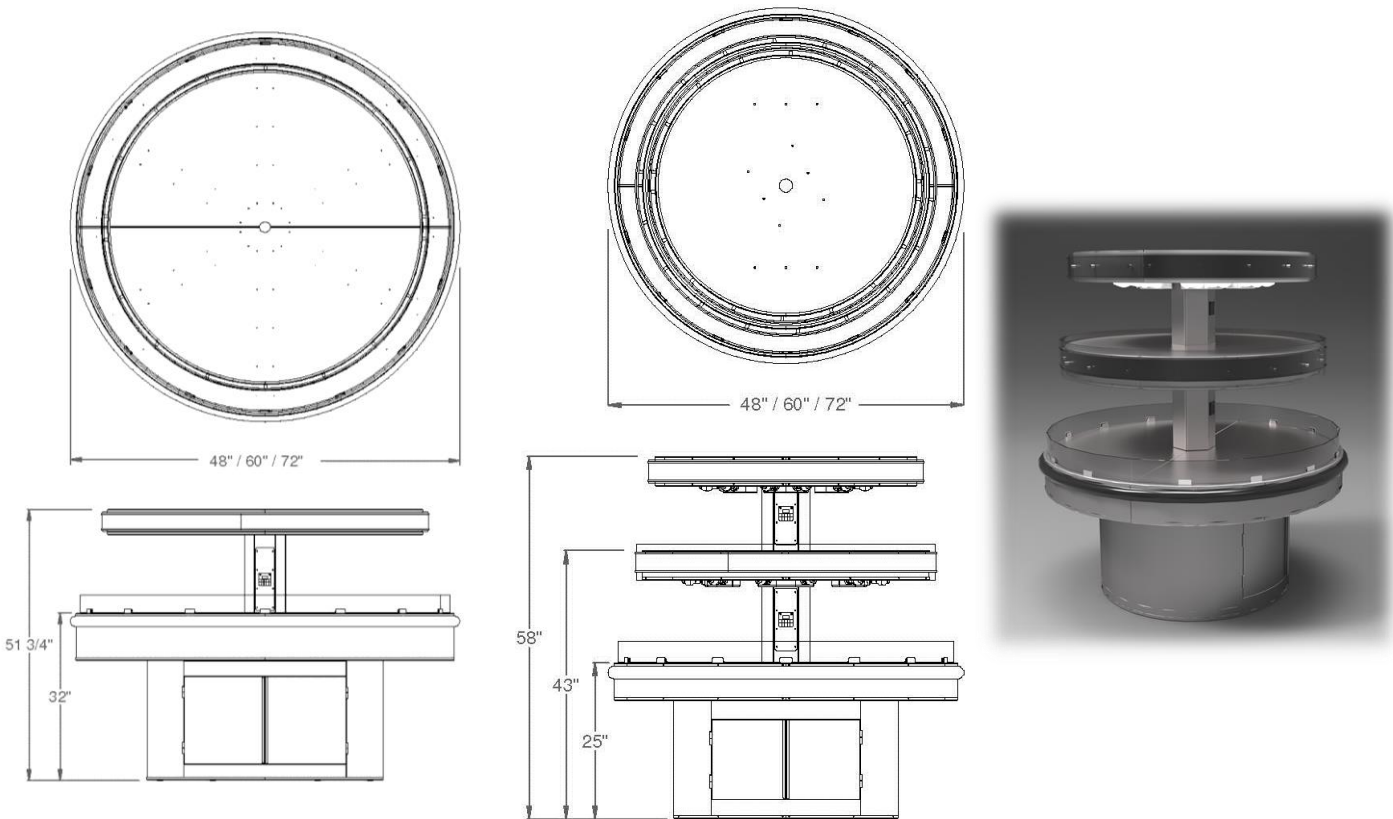

IP Code	Levels	O.A. Dimensions Diameter x Height	Capacity – Chicken Domes	Voltage
RHP3636	1	38" D x 52" H	8	120/208
RHP3636T	2	38" D x 58"H	14	120/208
RHP4848	1	50" D x 52" H	20	120/208
RHP4848T	2	50" D x 58"H	30	120/208
RHP5555	1	57" D x 52"H	24	120/208
RHP5555T	2	57" D x 58"H	38	120/208
RHP6060	1	60" D x 52"H	34	120/208
RHP6060T	2	60" D x 58"H	58	120/208
RHP7272	1	72" D x 52"H	42	120/208
RHP7272T	2	72" D x 58"H	70	120/208



HOT
Atlantic Food Bars
Hot & Cold Food Equipment Specialists
 888-MEAL-SOLUTIONS (888-632-5765)
 info@atlanticfoodbars.com www.atlanticfoodbars.com



Options, accessories and features - create YOUR perfect merchandiser !

OPTIONAL 2nd HOT MERCHANDISING DECK

Increase your merchandising impact in the same foot print - no additional floor space required to boost your selling capacity! Base unit only increases by 6" in height, so maintaining accessibility is not a problem for your shoppers.

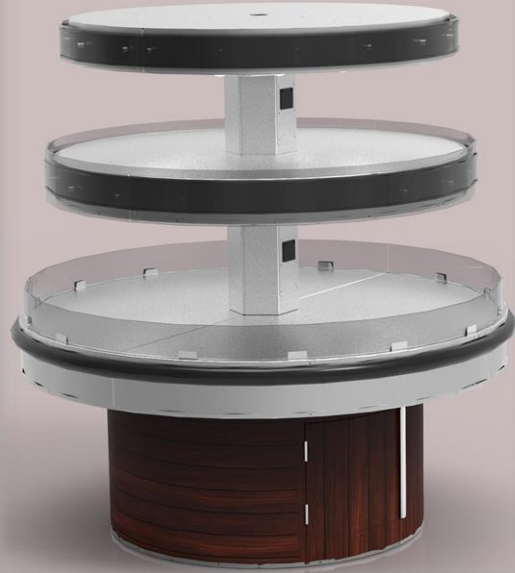
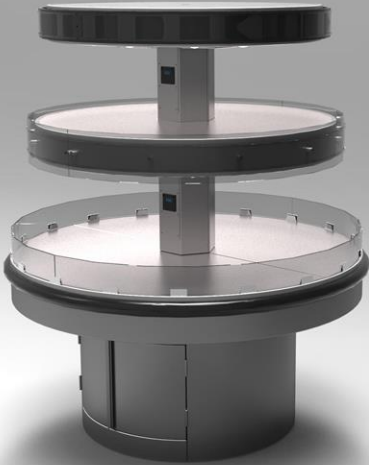

STAINLESS STEEL OR POWDER COATED BASE

Available in any color of your choice!

PRICE TAG MOLDING

Custom sign package included to help you sell-through your offerings with clear labeling from every angle of visibility!



INFINITE HEAT CONTROLS – EACH LEVEL

Easily monitor and manage the heat on each level INDIVIDUALLY with controls hidden behind the base hinged access doors so that you can sell different products at different heats on different shelves. Or, turn off the heat on lower shelf to display dry goods! Digital electronic thermometers included for each hot deck.

COLUMN WRAP 360° DISPLAY

Columns don't have to kill valuable selling space in your stores! Eliminate these sales and traffic impediments and hide their unsightliness - this feature allows you to turn dead space into beautiful merchandising centers. We can build the case in two halves to be installed around a column with any dimensions.

RHP Series Options & Accessories

**Celebrating 70
Years in 2017!**

Atlantic Food Bars

Hot & Cold Food Equipment Specialists

888-MEAL-SOLUTIONS (888-632-5765)

info@atlanticfoodbars.com

www.atlanticfoodbars.com

