

Make your Hot Grab & Go Food offerings a self service profit center with our WR Series Two Level Packaged Hot Food Merchandiser !



In a footprint as small as 36", you can increase your offering, create more impulse sales, and grow your hot food program. Based upon hourly and daily traffic patterns, you can utilize infinite temperature control for each individual hot deck to control shrink, maximizing your merchandising impact while continuing to maintain temperature.

This one or two level case is ideal, not just for rotisserie chicken, but for all packaged foods – turn off the heat on any given level to merchandise dry goods. If you are selling hot food full service, you won't believe the profitability of this self service unit due to reduced labor costs, convenience for shoppers, higher sales and lower shrink.

This unit is a **MONEY MAKER** and a **SELL-THROUGH BEAST !**



Two Level Packaged Hot Food Merchandiser

WR Series



HOT
Atlantic Food Bars
Hot & Cold Food Equipment Specialists
 888-MEAL-SOLUTIONS (888-632-5765)

info@atlanticfoodbars.com www.atlanticfoodbars.com



WR Series

Wrangler Two Level Packaged Hot Food Merchandiser



Standard Features

- Two level hot deck offers twice as much merchandising in the same linear space
- Infinite controls on bottom and top heat for each level
- Brilliant interior lighting on both levels showcases your hot meals
- Stainless steel interior and slanted stainless steel decks display food for optimal eye appeal
- Two rows of sign track with custom 3" tall signs in color and menu items of your choice
- Rear or front mounted controls in base allow in-line or wall installation
- Safety shields in front of both shelves protect children from touching the hot deck
- Stainless steel body and heavy duty protective bumper in colors of your choice

Options

- Entire body to be plastic laminate over stainless steel in lieu of #4 stainless steel
- Entire body to be powder coated steel in lieu of stainless steel
- Rounded profile
- Front Mounted Controls - include sliding access doors and closed rear on case - allows wall or end cap installation
- Clear ends, 2 each 1/2" thick
- Single or three phase breaker panel



HOT
Atlantic Food Bars
Hot & Cold Food Equipment Specialists

888-MEAL-SOLUTIONS (888-632-5765)

info@atlanticfoodbars.com www.atlanticfoodbars.com



WR Series

Wrangler Two Level Packaged Hot Food Merchandiser

Atlantic Food Bars WR Series Wrangler Two-Level Packaged Hot Food Merchandiser is covered by our INDUSTRY'S LONGEST WARRANTY – 2 year parts and labor. Warranty does not cover glass breakage or heat lamps, or abuse / misuse by operator. In line with its policy to continually improve its products, Atlantic Food Bars reserves the rights to change materials and specifications without notice.

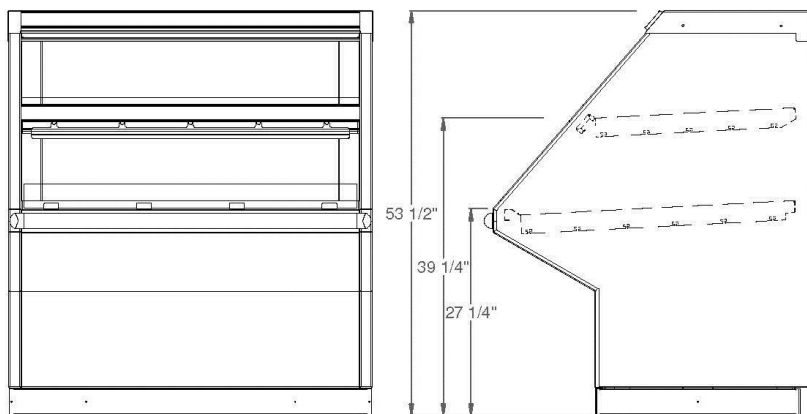
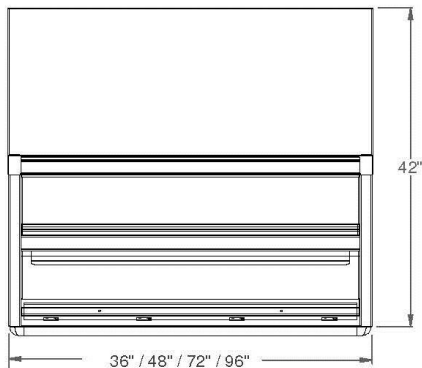

<i>IP Code</i>	<i>O.A. Dimensions L" x W" x H"</i>	<i>Capacity - Chicken Domes</i>	<i>Voltage</i>
WR3642	3'-0" x 43" x 53 1/2"	23	120/208
WR4842	4'-0" x 43" x 53 1/2"	29	120/208
WR6042	5'-0" x 43" x 53 1/2"	35	120/208
WR7242	6'-0" x 43" x 53 1/2"	45	120/208
WR9642	8'-0" x 43" x 53 1/2"	57	120/208



Atlantic Food Bars
Hot & Cold Food Equipment Specialists

888-MEAL-SOLUTIONS (888-632-5765)

info@atlanticfoodbars.com

www.atlanticfoodbars.com



NEXT GENERATION

~ Features ~



LED LIGHTING ON EACH LEVEL

The industry's most brilliant interior LED lighting on all levels showcases your hot offering, attracting customers like moths to a flame! Benefit from longer life, reduced maintenance costs on burned out bulbs, and energy conservation.

NEW SIMPLER DESIGN

Updated design allows for easier serviceability and attracts customer attention like no other case in the industry.

DIGITAL THERMOSTATS IN LIEU OF INFINITE CONTROLS ON DECK HEAT

More accurate temperature control so that you can sell product at exactly the right set point.



FULL WIDTH TOP HEAT PLATEN

More even heat distribution and temperature across the entire width of the hot shelf.

THIN PROFILE SHELVES

Your product is the focus, not the equipment – and customers can see even more of your fresh prepared food offerings with thin shelves offering the same reliable heat coverage.



Atlantic Food Bars

WRGCL-NXG Series



HOT

Atlantic Food Bars

Hot & Cold Food Equipment Specialists

888-MEAL-SOLUTIONS (888-632-5765)

info@atlanticfoodbars.com

www.atlanticfoodbars.com



Options, accessories and features - create the perfect merchandiser for YOUR food service operation!

**ANY FINISH - LAMINATED,
POWDER COATED OR STAINLESS**

Have it any way you want it, in any color of your choice to match your store's décor!



**POPULAR SIZES FROM 2' LONG
TO 12' LONG - CAN BE BUILT IN
ANY SIZE DESIRED, TO THE INCH!**

No engineering or design fees for changes!



**MATCH ANY PROFILE IN A LINEUP
- WHETHER THE ABUTTING CASE
WAS BUILT BY US OR A
COMPETITOR!**

We will match specs to keep consistency within your store.



**CONTROLS MOUNTED ON BACK OR
FRONT FOR END CAP / IN-LINE USE**

Case can be built to include sliding access doors on the base of the front side for employee ease of use in end cap / in-line applications. Rear of case can be designed as open or closed.

**Two Level Packaged Hot Food
Merchandiser**

WR Series



HOT
Atlantic Food Bars
Hot & Cold Food Equipment Specialists

888-MEAL-SOLUTIONS (888-632-5765)

info@atlanticfoodbars.com

www.atlanticfoodbars.com

