

**Wrangler™**

**Two Tier Rotisserie Chicken &  
Hot Packaged Food Merchandiser**

IP # WR7243-BP3-RP-UO  
6'-0" L x 40" D x 53 1/2" H

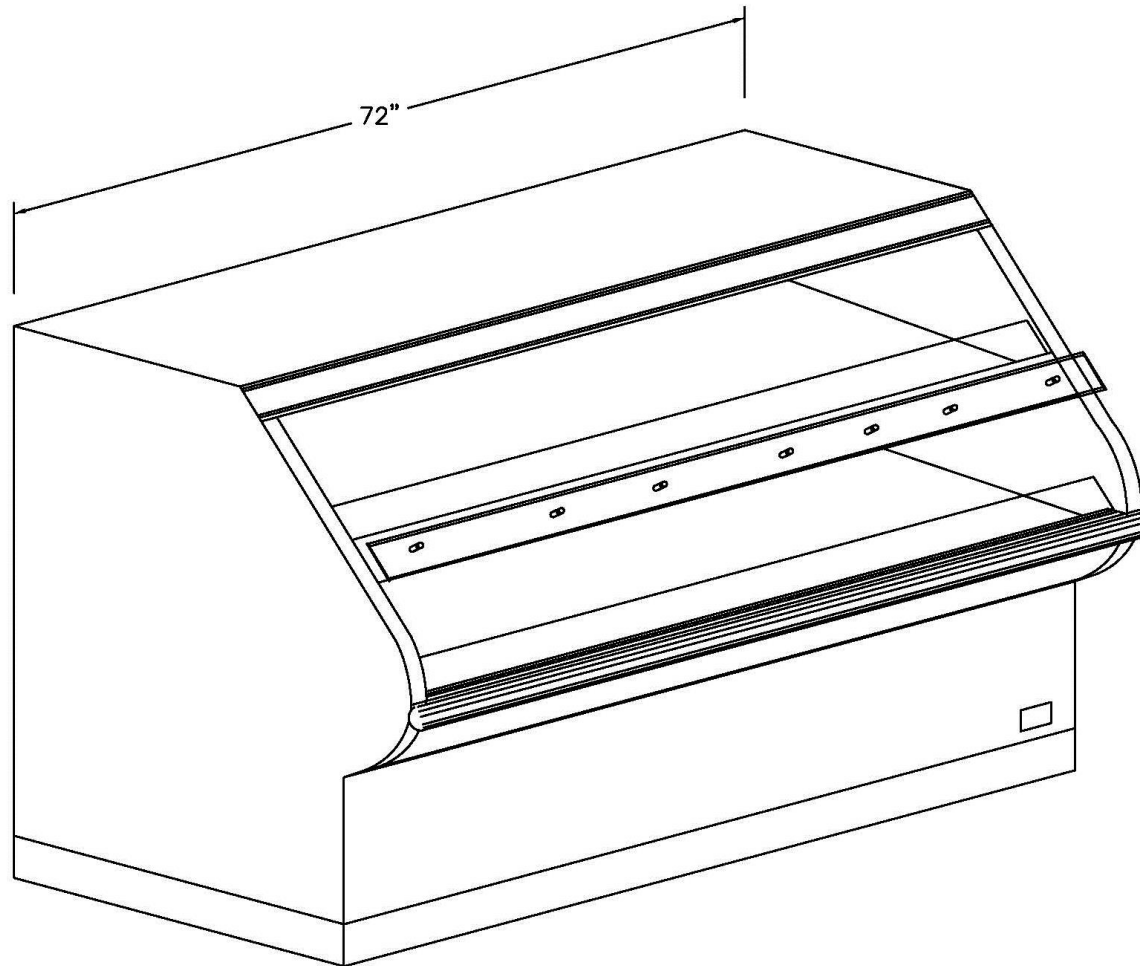

**Approval – Complete All Sections**

**Colors:**

Body: Stainless Steel  
Bumper: Black  
Countertop: Stainless Steel

**Electric :**

Voltage 120/208V  
Phase : 3 Phase  
Source : Floor

**Delivery**

Site: Loading Dock \_\_\_ Ground Level \_\_\_

Delivery hours : \_\_\_\_\_

Depth of widest case is 40" which will fit through  
narrowest space between delivery point and install  
location Yes \_\_\_ No \_\_\_ If no – CALL US ASAP

**Approval signature:** \_\_\_\_\_

**Date:** \_\_\_\_\_

*See last page for specifications table – your  
signature above verifies the installation site has the  
required power as shown*



**Atlantic Food Bars**

Your **HOT** & **COLD** Food Equipment Specialist !

888-MEAL-SOLUTIONS (888-632-5765)

[www.atlanticfoodbars.com](http://www.atlanticfoodbars.com)

# Wrangler™

## Two Tier Rotisserie Chicken & Hot Packaged Food Merchandiser

IP # WR7243-BP3-RP-UO

6'-0" L x 40" D x 53 1/2" H

Details per sign off on page 1 and specifications on page 2

Approval signature: \_\_\_\_\_

Date: \_\_\_\_\_

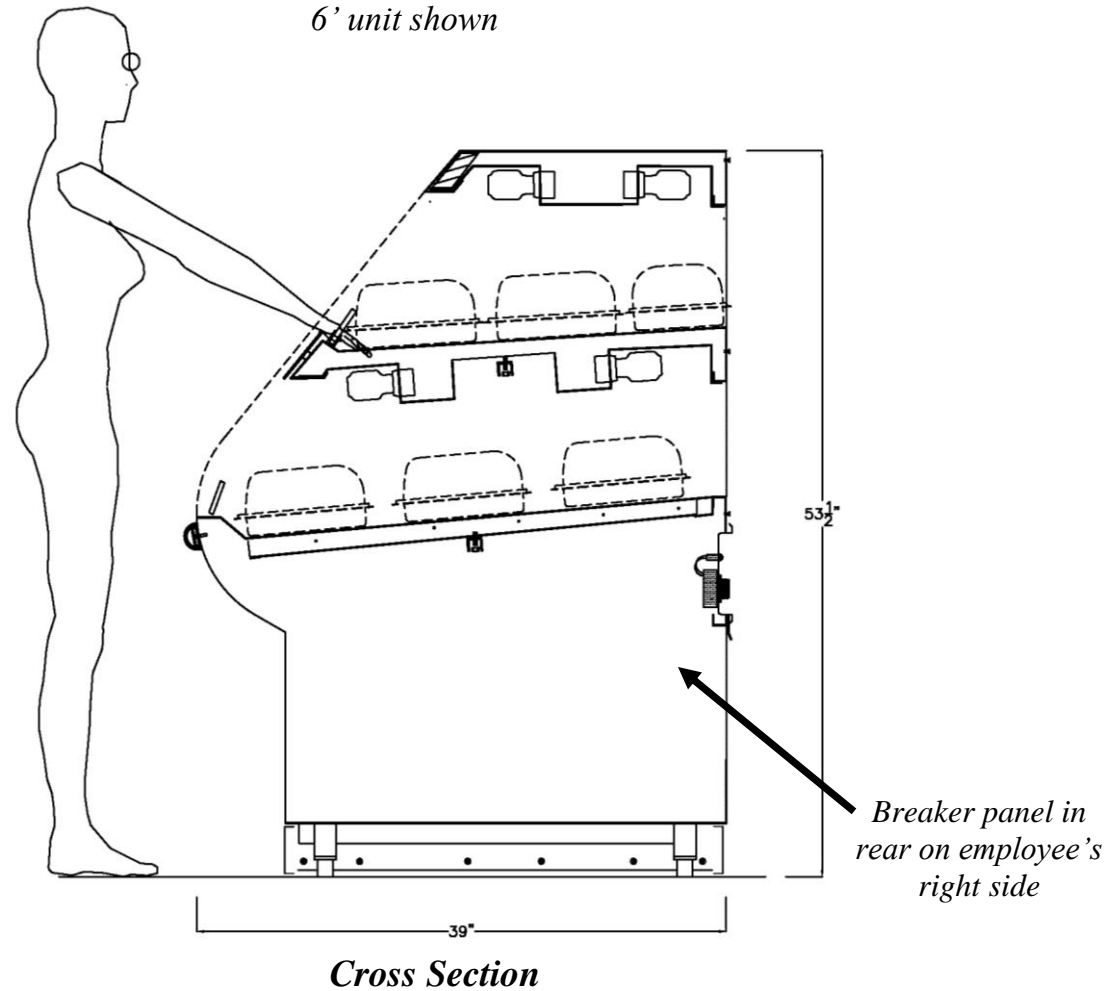

Internal Part #	Custom Description	Dimensions	Voltage	Amps 3 Ph	Chicken Capacity
WR7243-BP3-RP	6' Two-Tier Packaged Hot Food Merchandiser	6'-0" L x 40" D x 53 1/2" H	120/208	30	54

Maximum overcurrent protection = 40 amps. Requires #8 wire



**Atlantic Food Bars**

Your **HOT & COLD** Food Equipment Specialist !

888-MEAL-SOLUTIONS (888-632-5765)

[www.atlanticfoodbars.com](http://www.atlanticfoodbars.com)