

Full Service Hot Carving Station

with Flush Mounted Hot Plates

IP #IPS10240-W-GC-UO

116" L x 40" D x 60-1/2" H

Scroll down for more views

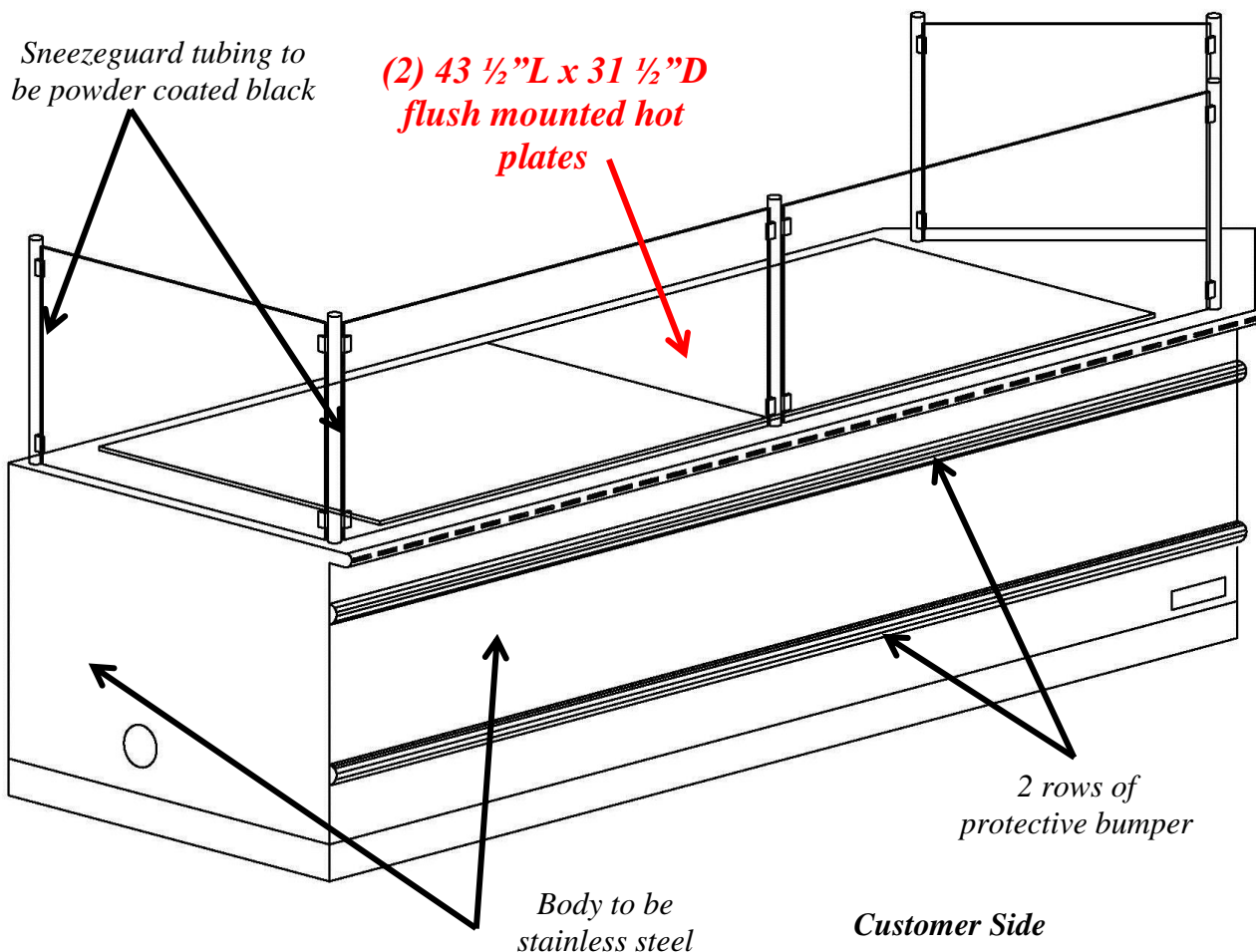

Approval – Complete All Sections

Colors:

Body: Stainless Steel
Sneeze guard tubing: Powder coat black
Bumper: black
Countertop: _____

Electric:

Voltage: 120V (see last page)
Phase: Single
Source: Floor

Delivery

Site: Loading Dock ___ Ground Level ___
Delivery hours : _____
Depth of case is 40" which will fit through narrowest space between delivery point and install location **Yes ___ No ___ If no – CALL US ASAP**

Approval signature: _____

Date: _____

See last page for specifications table – your signature above verifies the installation site has the required power as shown



HOT
Atlantic Food Bars
Hot Food Merchandising
Equipment Specialists

888-MEAL-SOLUTIONS
(888-632-5765)
www.atlanticfoodbars.com

Full Service Hot Carving Station

with Flush Mounted Hot Plates

IP #IPS10240-W-GC-UO

116" L x 40" D x 60-1/2" H

Details per sign off on page 1 and specifications on last page

Approval signature: _____

Date: _____

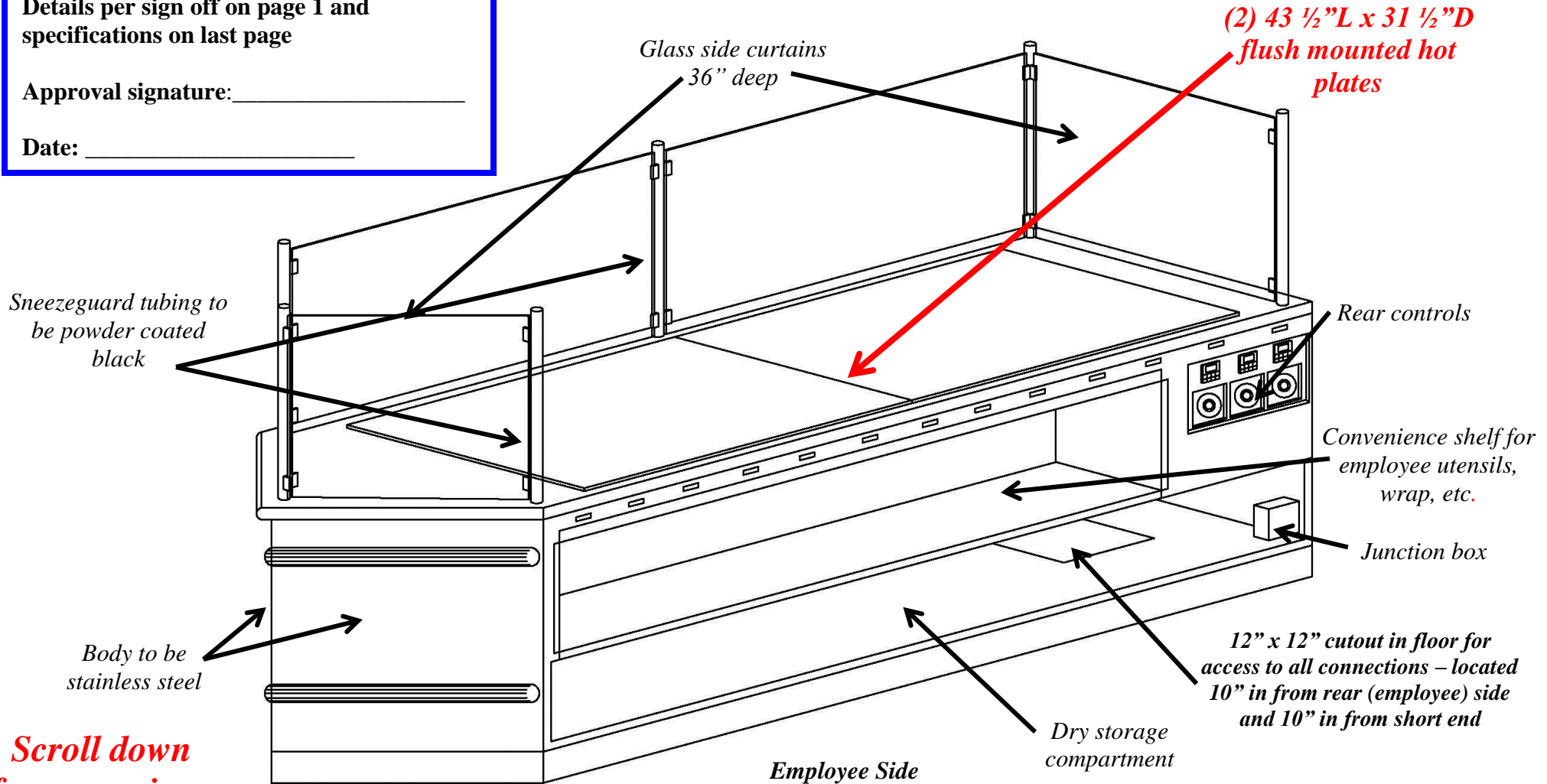

Scroll down for more views



HOT
Atlantic Food Bars
Hot Food Merchandising
Equipment Specialists

888-MEAL-SOLUTIONS
(888-632-5765)
www.atlanticfoodbars.com

Full Service Hot Carving Station

with Flush Mounted Hot Plates

IP #IPS10240-W-GC-UO

116"L x 40" D x 60-1/2" H

Details per sign off on page 1 and specifications on last page

Approval signature: _____

Date: _____

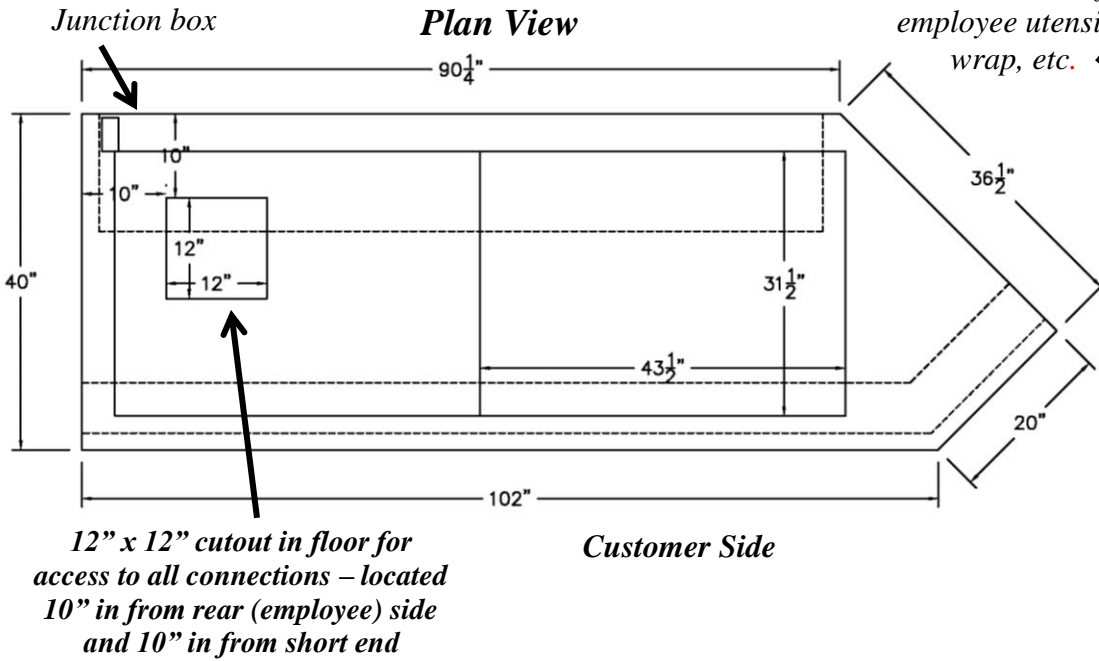

Glass side curtains 36" deep

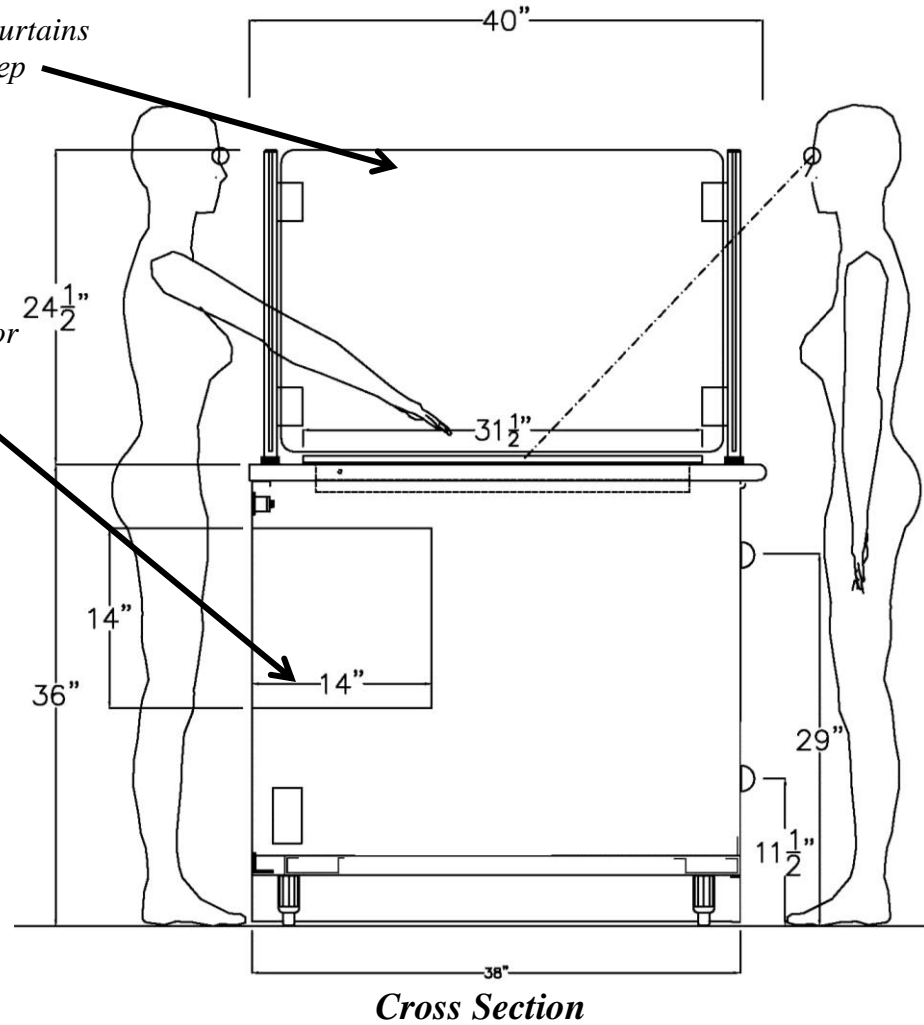

Convenience shelf for employee utensils, wrap, etc.

Internal Part #	Custom Description	Dimensions	Voltage	Amps 1 Ph
IPS10240-W-GC-UO	Hot Carving Station with Wedge End	102" L x 20"L x 40" D x 60 1/2" H	120	21.2
Maximum overcurrent protection = 30 amps				



Countertop Two Level Rotisserie Chicken & Hot Packaged Food Merchandiser

On Stainless Steel Base

IP #Custom

38" L x 25" D x 56" H

Powder coated
framework on
countertop
chicken warmer

Two levels of hot
packaged food
merchandising

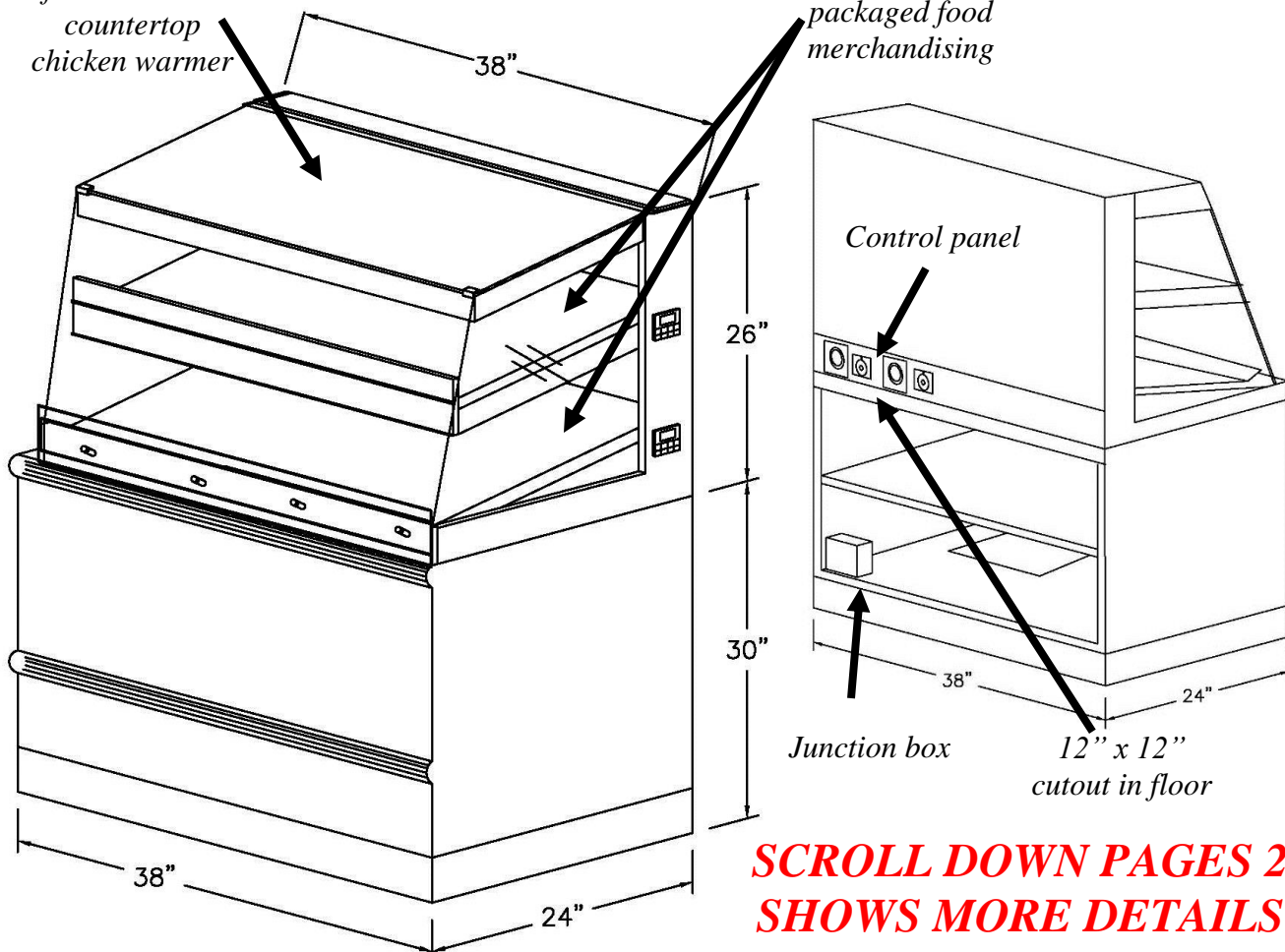

**SCROLL DOWN PAGES 2
SHOWS MORE DETAILS**

Approval – Complete All Sections

Colors:

Base: Stainless Steel
Framework for 2-level warmer: Powder coat
black
Bumper: black
Hot Decks: Stainless Steel

Electric :

Voltage 120V
Phase : Single
Source : Floor

Delivery

Site: Loading Dock Ground Level

Delivery hours : _____

Depth of case is 25" which will fit through
narrowest space between delivery point and install
location Yes No If no – CALL US ASAP

Approval signature: _____

Date: _____

See last page for specifications table – your
signature above verifies the installation site has the
required power as shown



HOT
Atlantic Food Bars
Hot Food Merchandising
Equipment Specialists

888-MEAL-SOLUTIONS
(888-632-5765)
www.atlanticfoodbars.com

Countertop Two Level Rotisserie Chicken & Hot Packaged Food Merchandiser

On Stainless Steel Base

IP #Custom
38" L x 25" D x 56" H

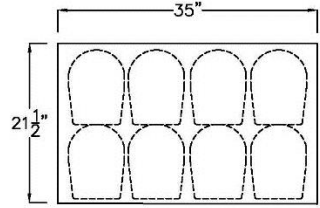

TOP DECKS CHICKEN BOATS

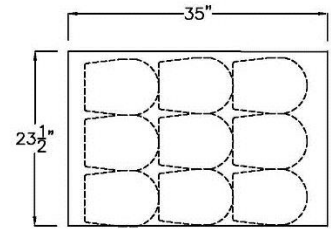

BOTTOM DECKS CHICKEN BOATS

Details per sign off on page 1 and specifications on last page

Approval signature: _____

Date: _____

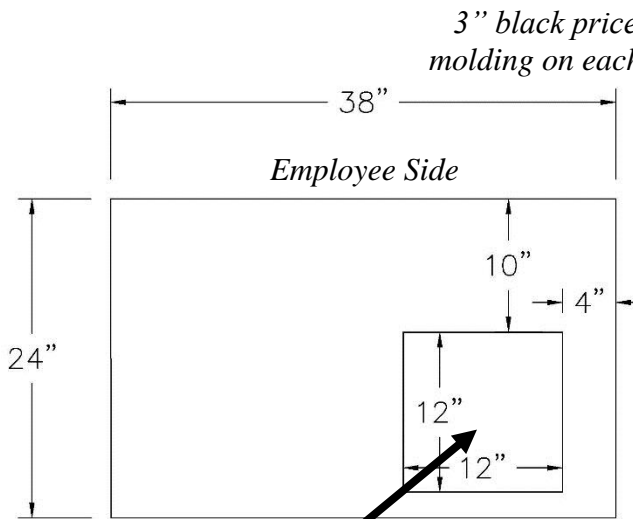

12" x 12" cutout in floor for access to all connections – located 10" in from rear and 4" in from short end

All stainless steel base with 2 rows of protective bumper

Top and bottom heat on each level

3" black price tag molding on each level

Cross section

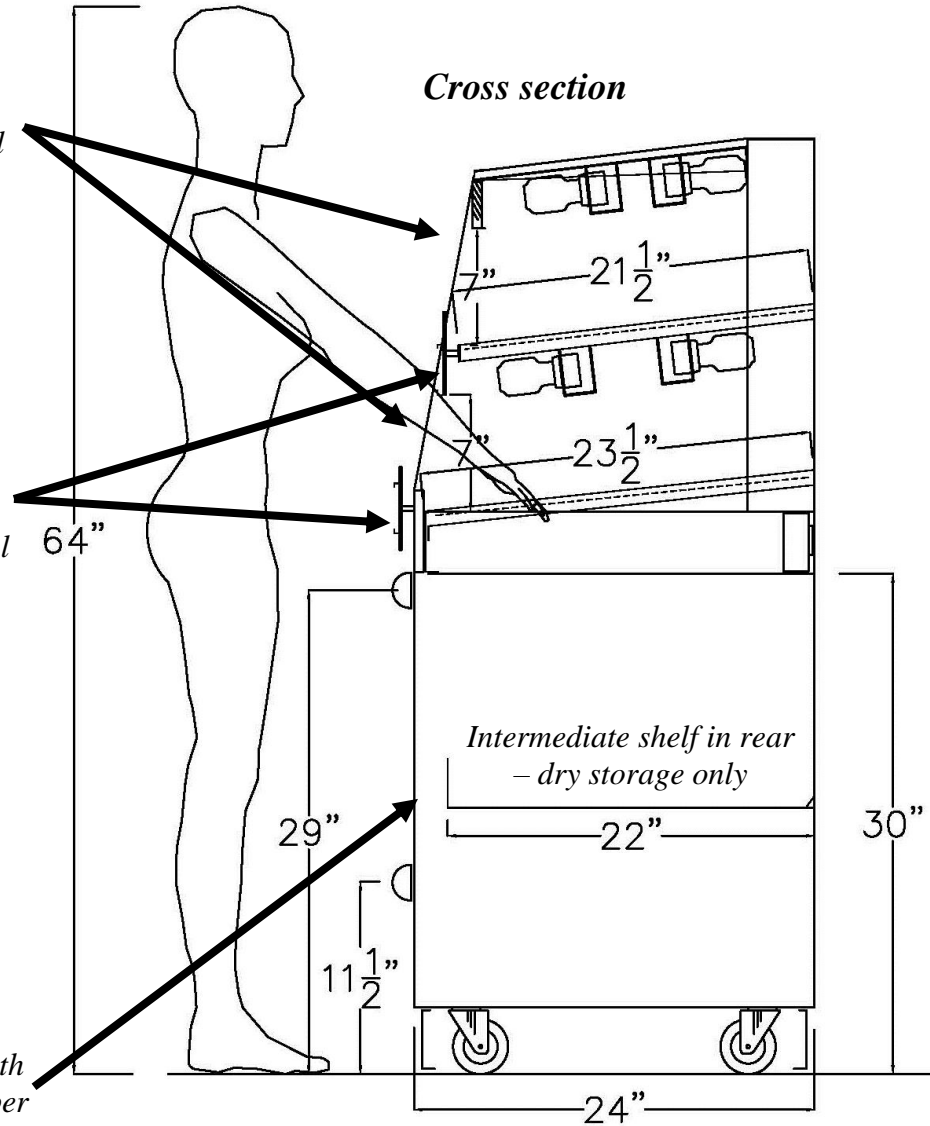

Internal Part #	Custom Description	Dimensions	Voltage	Amps I Ph	Chicken Capacity
Custom	38" Countertop Chicken Warmer on Stainless Base	38" L x 25" D x 56" H	120	24.5	17
Requires 40-amp circuit					



HOT
Atlantic Food Bars
Hot Food Merchandising
Equipment Specialists

888-MEAL-SOLUTIONS (888-632-5765)
www.atlanticfoodbars.com