

10' In-Line Full-Service Hot Food Merchandiser

IP# SHFB12040-BP3-CM-LB
10'-0" L x 41" D x 54" H

2 each scale platforms

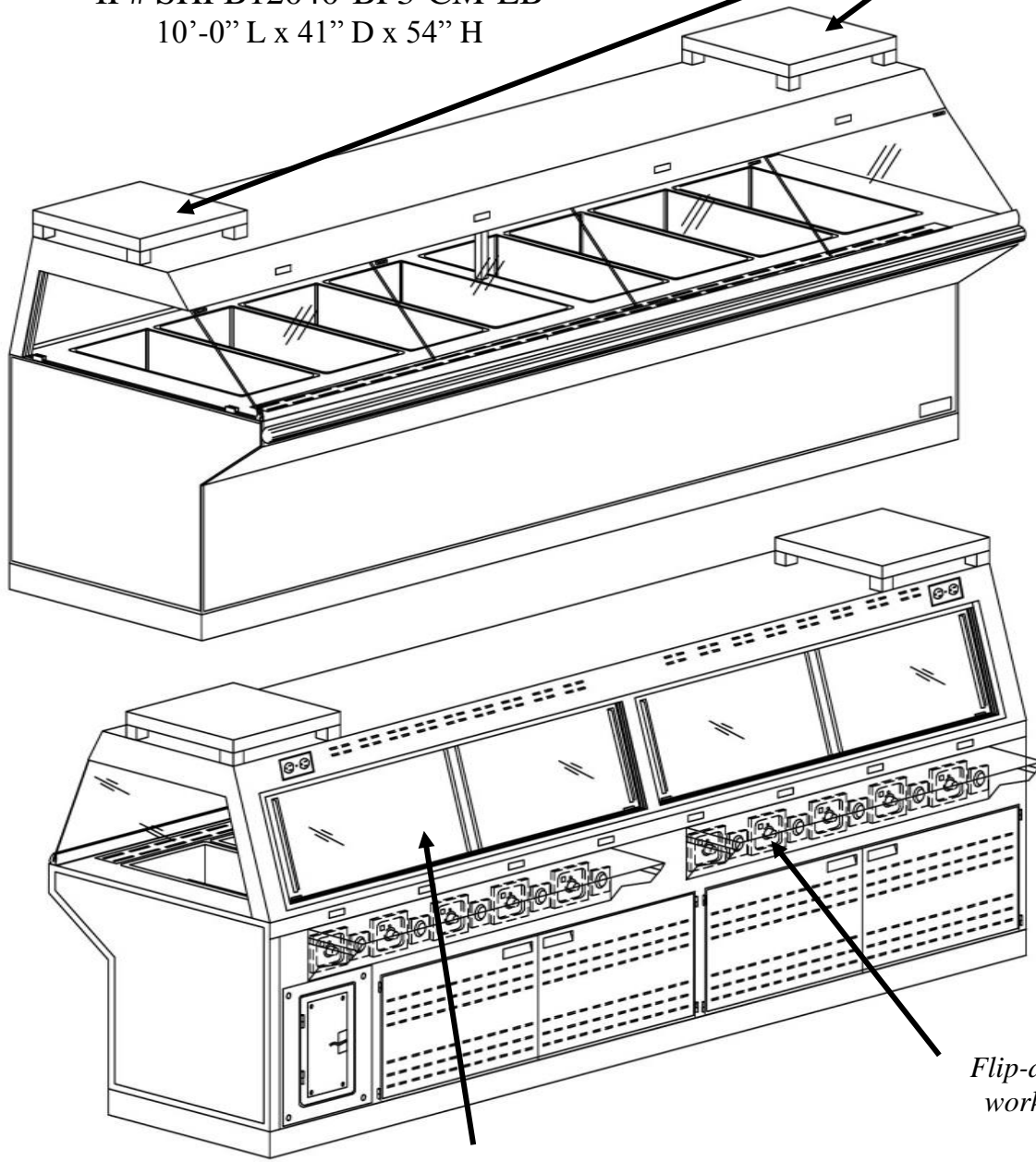

Sliding rear mirrored doors

Flip-down poly work shelves

Approval – Complete All Sections

Colors:

Body: black
Bumper: black
Countertop: Stainless Steel

Electric:

Voltage: 120/208V
Phase: Three
Source: Floor

Delivery

Site: Loading Dock Ground Level

Delivery hours:

Depth of case is 41" which will fit through narrowest space between delivery point and install location Yes No If no – CALL US ASAP

Approval signature:

Date:

See next page for specifications table – your signature above verifies the installation site has the required power as shown

Scroll down for more details



HOT
Atlantic Food Bars
Hot Food Merchandising
Equipment Specialists

888-MEAL-SOLUTIONS (888-632-5765)
www.atlanticfoodbars.com

10' In-Line Full-Service Hot Food Merchandiser

IP# SHFB12040-BP3-CM-LB

10'-0" L x 41" D x 54" H

Details per sign off on page 1 and specifications on this page

Approval signature: _____

Date: _____

8 ea. 12" x 27" hot wells

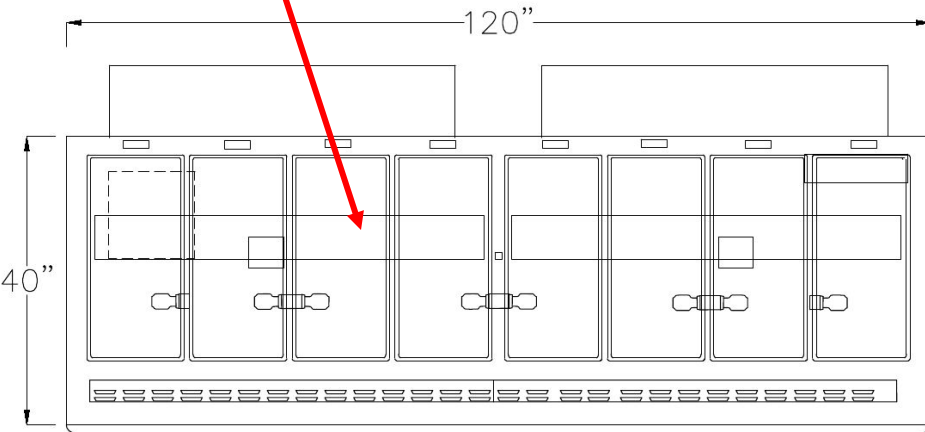

Plan View

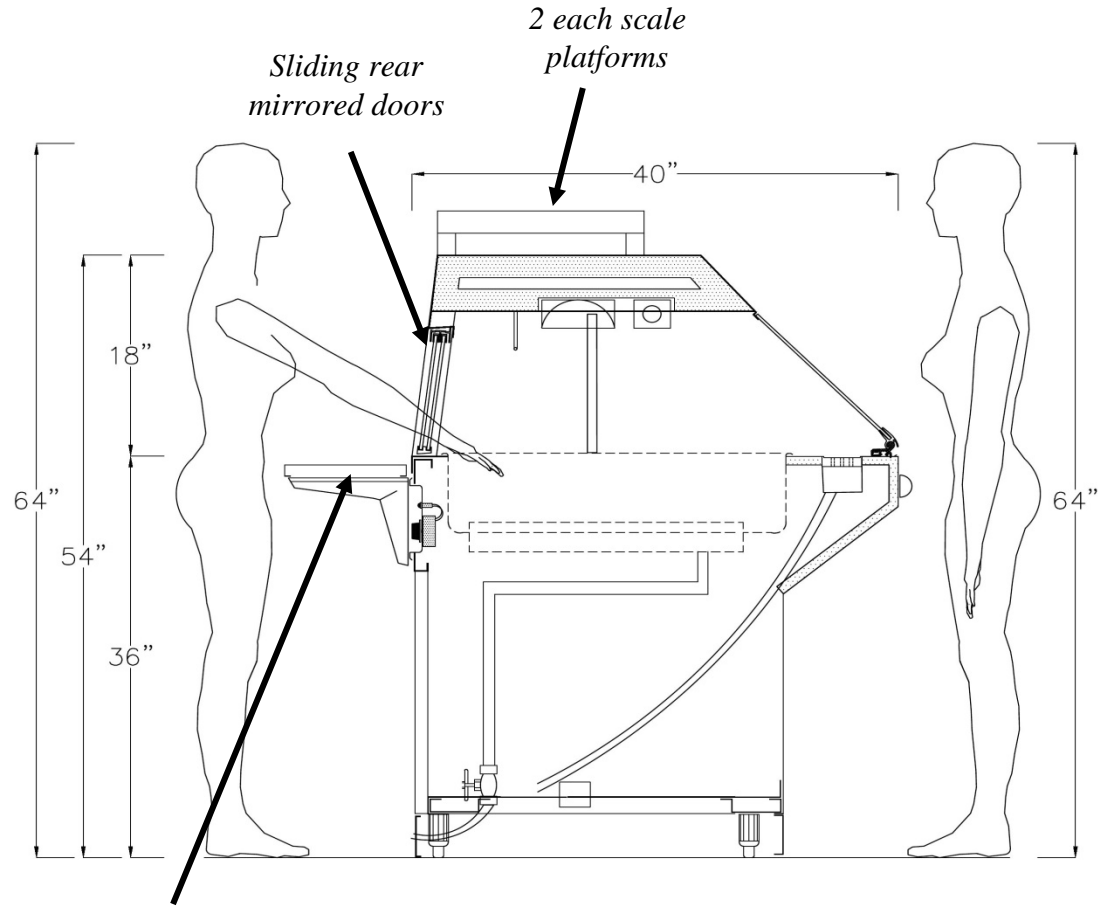

Cross Section

Flip-down poly work shelves

Internal Part #	Custom Description	Dimensions	Voltage	Amps 3ph	12" x 27" Hot Pan Openings
SHFB12040-BP3-CM-LB	10' In Line Full Service Hot Food Merchandiser	10'-0" L x 41" D x 54" H	120/208	59.0	8
Requires 80-amp circuit breaker (with scale platforms and duplex receptacles)					

HOT
Atlantic Food Bars
 Hot Food Merchandising
 Equipment Specialists
 888-MEAL-SOLUTIONS (888-632-5765)