

HEX-A-HOT™

One Tier Island Hot Packaged Food Hexagon

IP #HXH7263-BP3-PCB
6'-2" L x 64 1/2" D x 50-3/4" H

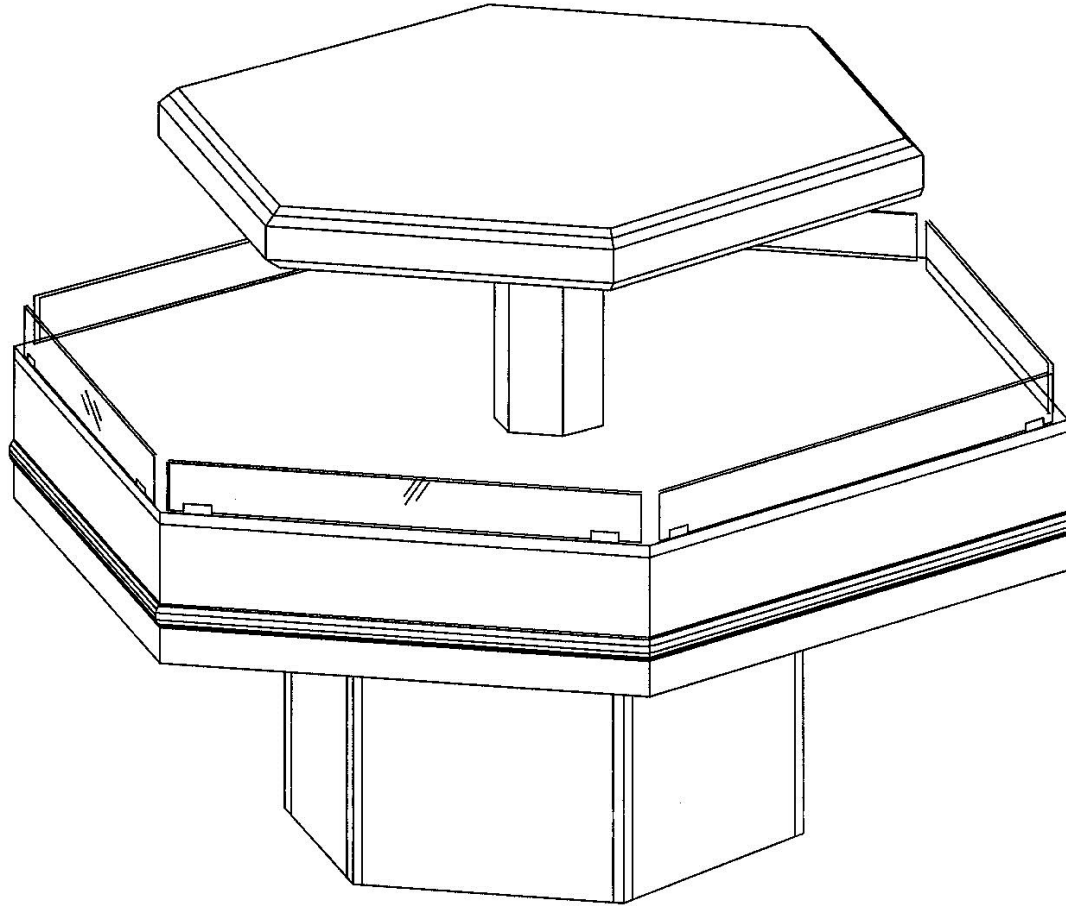

Approval – Complete All Sections

Colors:

Body:

Powder Coat – RAL BM #2007-10 Smoldering Red

Bumper: Black

Electric:

Voltage 120/208V

Phase: Three

Delivery

Site: Loading Dock ___ Ground Level ___

Delivery hours: _____

Depth of case is 74" which will fit through narrowest space between delivery point and install location

Yes ___ No ___ If no – CALL US ASAP

Approval signature: _____

Date: _____

See last page for specifications table – your signature above verifies the installation site has the required power as shown

Scroll down for more views



HOT
Atlantic Food Bars
Hot Food Merchandising
Equipment Specialists

888-MEAL-SOLUTIONS
(888-632-5765)
www.atlanticfoodbars.com

HEX-A-HOT™

One Tier Island Hot Packaged Food Hexagon

IP #HXH7263-BP3-PCB
6'-2" L x 64 1/2" D x 50-3/4" H

Details per sign off on page 1 and specifications on last page

Approval signature: _____

Date: _____

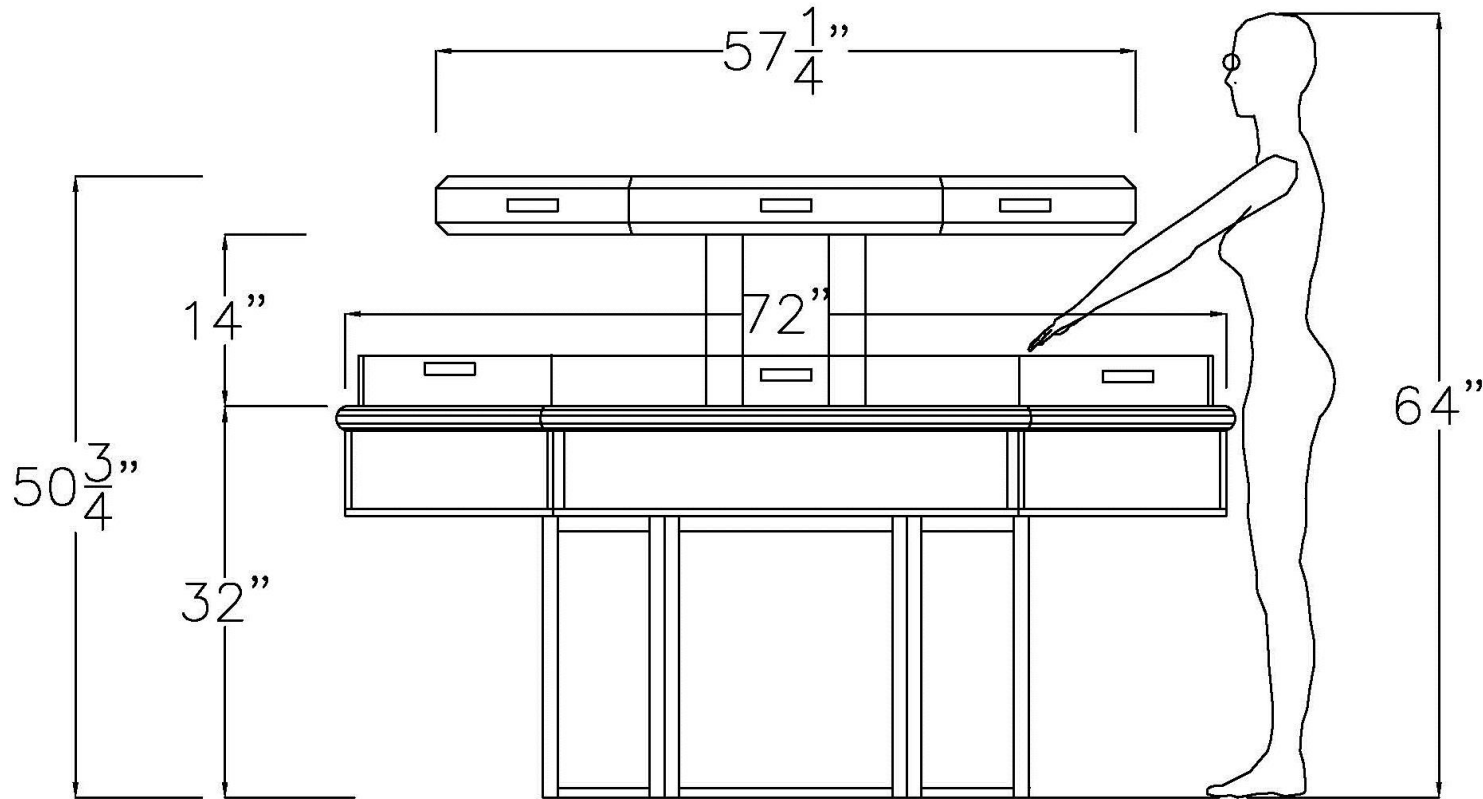

Cross Section

Internal Part #	Custom Description	Dimensions	Voltage	Amps 3 Ph	Chicken Capacity
HXH7263-BP3-PCB	6' Single Tier Island Hot Packaged Food Hexagon	6'-2" L x 65" D x 50-3/4" H	120/208	19.3	40

Celebrating 70 Years in 2017!



Atlantic Food Bars
Hot Food Merchandising
Equipment Specialists

888-MEAL-SOLUTIONS (888-632-5765)
www.atlanticfoodbars.com