

**Give your Hot Grab & Go Food display 360 degree shop-around appeal with our HXH Series HEX-A-HOT™ One-Level Island Packaged Hot Food Merchandiser !**



HXH7263 Shown

This shop-around case is ideal, not just for rotisserie chicken, but for all packaged foods – sandwiches – ribs – entrees – sides . . . If you are selling hot food full service, you won't believe the profitability of this self-service unit due to increased sales resulting from shopper impulse, reduced labor costs, and lower shrink.

This unit is a **MONEY MAKER** and a **SELL-THROUGH BEAST !**

Create more impulse sales and grow your hot food program! Recessed base provides a perfect space where our customers have created imaginative ways to show complementary products – more impulse sales opportunities



HXH5648 Shown with Laminated Finish

**HXH Series One-Level Island Grab & Go Packaged Hot Food Merchandiser**



**HOT**  
**Atlantic Food Bars**  
**Hot & Cold Food Equipment Specialists**

888-MEAL-SOLUTIONS (888-632-5765)  
 info@atlanticfoodbars.com www.atlanticfoodbars.com



# HXH Series *HEX-A-HOT*™

## One-Level Island Grab & Go Packaged Hot Food Merchandiser

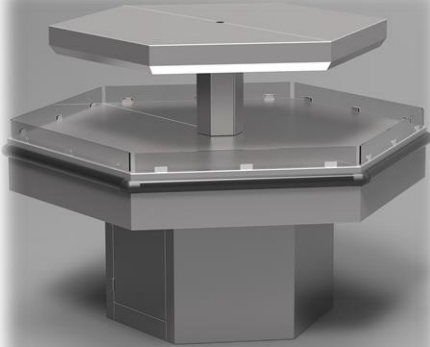

HXH7263 Shown with Stainless Steel Finish

### Standard Features – 1, 2 and 3 Level Cases

- Atlantic's exclusive top heat and light system provides full coverage heat, reduced maintenance costs and brilliant illumination on each level which attracts shoppers' attention and builds impulse sales.
- The industry's most reliable and maintenance-free bottom heat system
- User friendly control package with digital thermostatic temperature controls for hot deck and on/off switches for top heat and lighting
- Welded all steel construction means this case will NEVER let you down !
- Heavy gauge stainless steel decks are easy to clean
- Easily accessible controls hidden in base behind access door
- Clear safety / draft shields around decks offer safety and help protect against cross drafts
- Plastic tag molding on all levels offers simplicity in signage
- Digital solar thermometer on EACH level
- Stainless steel body and heavy-duty protective bumper in colors of your choice



2-Tier HXH-T Shown with Stainless Steel Finish

3-Tier HXH-TD  
Shown with Powder  
Coated Finish



### Options

- Wrap-around column 2-piece design
- Base to be powder coated in lieu of stainless steel
- Laminated base in color of your choice in lieu of stainless steel
- Electric feed through top of case
- Soup wells in lieu of flat hot deck



**HOT**  
**Atlantic Food Bars**  
**Hot & Cold Food Equipment Specialists**

888-MEAL-SOLUTIONS (888-632-5765)

info@atlanticfoodbars.com    www.atlanticfoodbars.com



# HXH Series *HEX-A-HOT*™

## One-Level Island Grab & Go Packaged Hot Food Merchandiser

**Atlantic Food Bars** HXH Series One-Level Island Grab & Go Packaged Hot Food Merchandiser are covered by our INDUSTRY'S LONGEST WARRANTY – 2 year parts and labor. Warranty does not cover glass breakage or heat lamps, or abuse / misuse by operator. In line with its policy to continually improve its products, Atlantic Food Bars reserves the rights to change materials and specifications without notice.

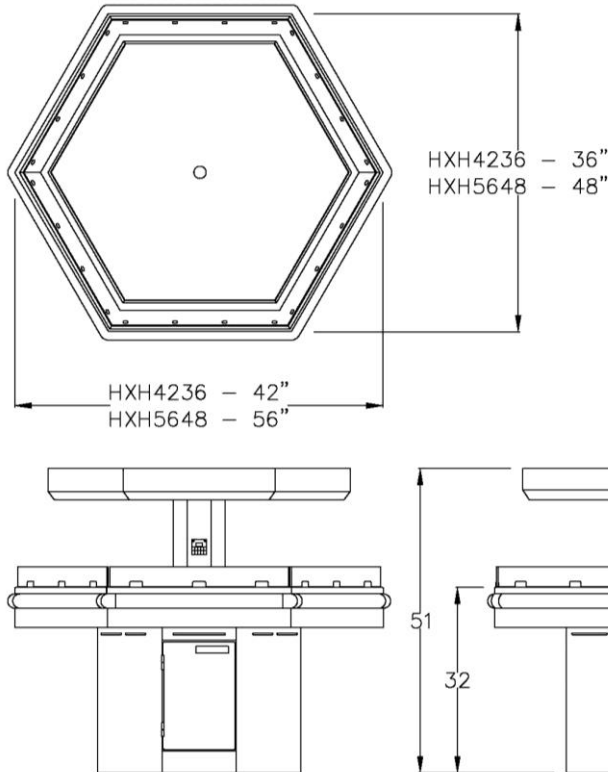

HXH5648 Shown with Stainless Steel Finish

IP Code	O.A. Dimensions L" x W" x H"	Capacity – Chicken Domes	Voltage
			120/208
HXH4236	42" x 36" x 63"	9 Chickens	120/208
HXH5648	56" x 48" x 63"	22 Chickens	120/208
HXH6556	65" x 56" x 63"	30 Chickens	120/208
HXH7263	72" x 63" x 63"	40 Chickens	120/208



**Hot**  
**Atlantic Food Bars**  
**Hot & Cold Food Equipment Specialists**

888-MEAL-SOLUTIONS (888-632-5765)

info@atlanticfoodbars.com    www.atlanticfoodbars.com



# HXH-T Series *HEX-A-HOT*™

## TWO-Level Island Grab & Go Packaged Hot Food Merchandiser

**Atlantic Food Bars** HXH Series One-Level Island Grab & Go Packaged Hot Food Merchandiser are covered by our INDUSTRY'S LONGEST WARRANTY – 2 year parts and labor. Warranty does not cover glass breakage or heat lamps, or abuse / misuse by operator. In line with its policy to continually improve its products, Atlantic Food Bars reserves the rights to change materials and specifications without notice.

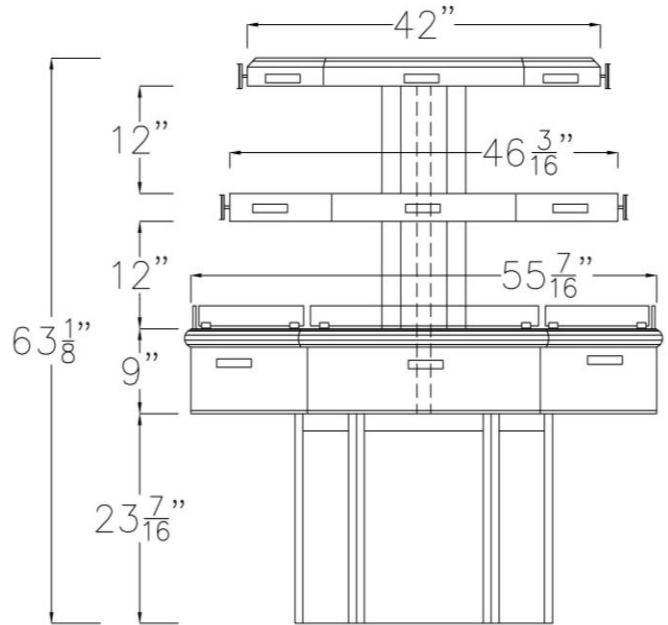

IP Code	O.A. Dimensions L" x W" x H"	Capacity – Chicken Domes	Voltage
			HXH4236-T
HXH5648-T	56" x 48" x 63"	38 Chickens	120/208
HXH6556-T	65" x 56" x 63"	50 Chickens	120/208
HXH7263-T	72" x 63" x 63"	66 Chickens	120/208



**HOT**  
**Atlantic Food Bars**  
**Hot & Cold Food Equipment Specialists**

888-MEAL-SOLUTIONS (888-632-5765)

info@atlanticfoodbars.com    www.atlanticfoodbars.com



# HXH-TD Series *HEX-A-HOT*™

## THREE-Level Island Grab & Go Packaged Hot Food Merchandiser

**Atlantic Food Bars** HXH Series One-Level Island Grab & Go Packaged Hot Food Merchandiser are covered by our INDUSTRY'S LONGEST WARRANTY – 2 year parts and labor. Warranty does not cover glass breakage or heat lamps, or abuse / misuse by operator. In line with its policy to continually improve its products, Atlantic Food Bars reserves the rights to change materials and specifications without notice.

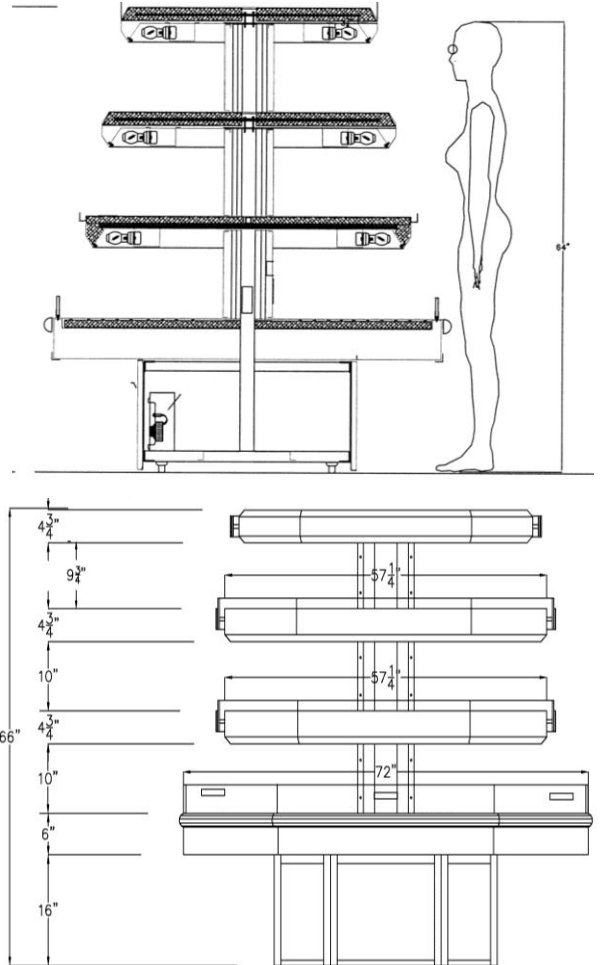

IP Code	O.A. Dimensions L" x W" x H"	Capacity – Chicken Domes	Electrical			
			Voltage	Amps 1Ø / 3Ø	Plug	MCA
HXH4236-TD	44" x 38" x 67"	22 Chickens	120/208	20.3A - 1Ø	14-30P	30
				11.3A - 3Ø	L21-20P	20
HXH5648-TD	58" x 50" x 67"	50 Chickens	120/208	35.3A - 1Ø	14-50P	50
				22.8A - 3Ø	L21-30P	30
HXH6556-TD	67" x 58" x 67"	69 Chickens	120/208	39.9A - 1Ø	L14-50P	50
				34.2A - 3Ø	HBL560P9W	50



**Hot**  
**Atlantic Food Bars**  
**Hot & Cold Food Equipment Specialists**

888-MEAL-SOLUTIONS (888-632-5765)

info@atlanticfoodbars.com    www.atlanticfoodbars.com



# Options, accessories and features create the perfect merchandiser for YOUR food service operation!

## MAX OUT YOUR MERCHANDISING WITH ONE, TWO OR THREE HOT LEVELS

Increase sales in a compact footprint by going vertical! This shop-around multi-deck case can offer as much or as little as you desire, in 3' / 4' / 5' / 6' standard configurations.



## INFINITE HEAT CONTROL - EACH INDIVIDUAL LEVEL

Control the top and bottom heat on each tier! Heat lamps and hot decks feature individual temperature control, allowing you to intelligently stock your case and minimize shrink based upon periods of fluctuating demand. Turn off the heat to merchandise dry goods at off-peak times, and pack it out and sell hot rotisserie chicken and packaged grab & go products when the time is right!

## COLUMN WRAP 360° DISPLAY

Columns don't have to kill valuable selling space in your stores! Forget about leaning cardboard product stands up against your store columns to hide their unsightliness - this feature allows you to turn dead space into beautiful merchandising centers. We can build the case in two halves to be installed around a column with any dimensions.



## SIGNAGE TRACK ON EVERY LEVEL

Multiple levels of sign track allow for easy, organized display of product signage. Your individual labels slide right into the price tag molding the moment you receive the merchandiser!



**HOT**

**Atlantic Food Bars**

**Hot & Cold Food Equipment Specialists**

888-MEAL-SOLUTIONS (888-632-5765)

info@atlanticfoodbars.com

www.atlanticfoodbars.com



**HXXH / HXXH-T / HXXH-TD Series Options & Features**