

# Island Express PLUS™

## Wide Three Tier Island Rotisserie Chicken & Hot Packaged Food Merchandiser with 3 Hot Shelves

IP # IMN7245-AS-BP3-LB

6'-2" L x 47" D x 66 1/4" H

**45" Wide Unit**

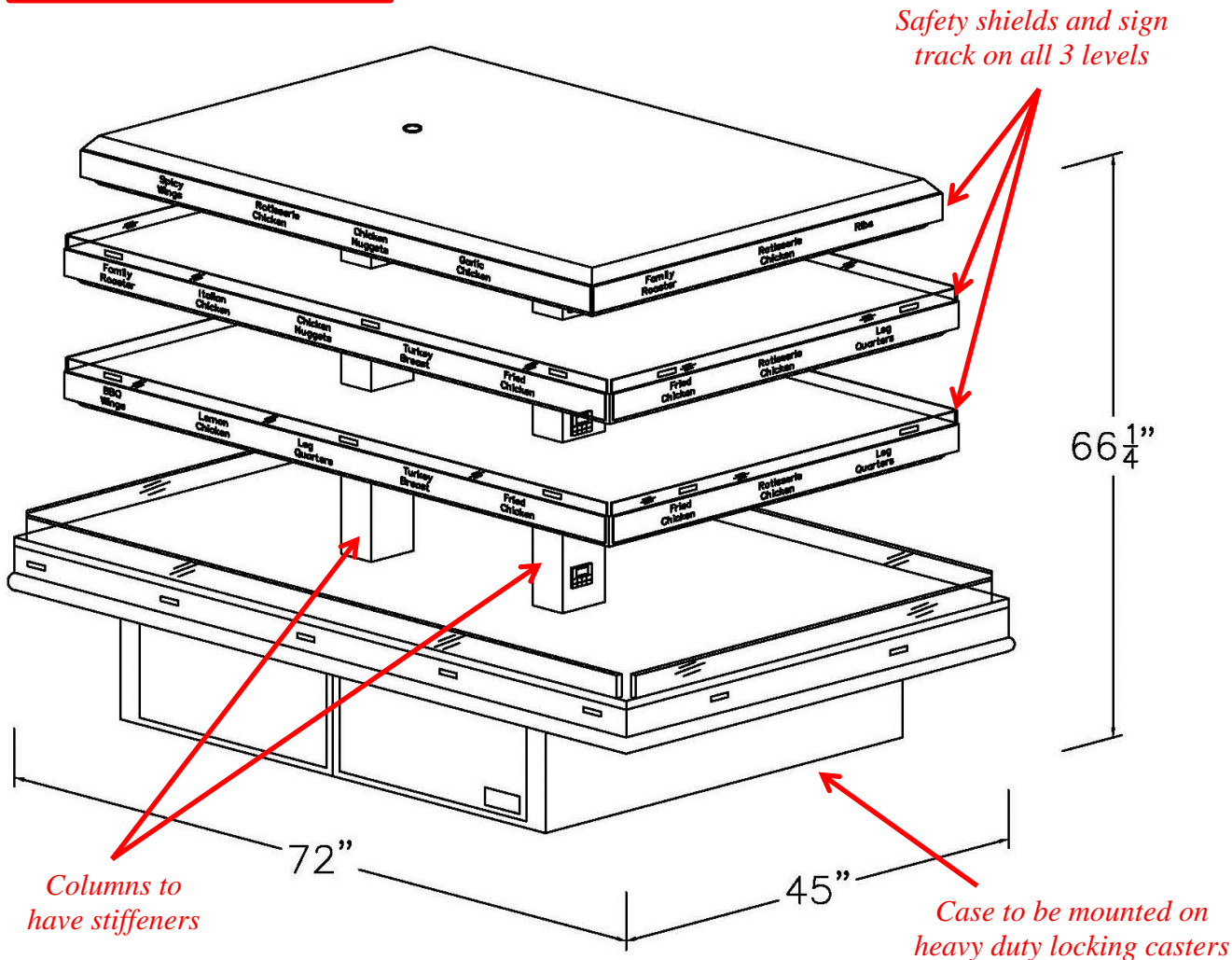

### Approval – Complete All Sections

#### Colors:

Body: Laminate: X Mfr: Wilsonart  
Color: #7969K-12 Warehouse Oak  
Woodgrain to run horizontally  
Hot Decks : #4 Satin finish stainless steel  
Bumper: Black  
Kickplate : Black

#### Electric:

Voltage 120/208V X  
Phase: Three X  
Source: Floor X

#### Delivery

Site: Loading Dock \_\_\_ Ground Level \_\_\_  
Delivery hours: \_\_\_  
Depth of case is 47" which will fit through narrowest space between delivery point and install location. Yes \_\_\_ No \_\_\_ If no – **CALL US ASAP**

Approval signature: \_\_\_\_\_

Date: \_\_\_\_\_

See last page for specifications table – your signature above verifies the installation site has the required power as shown



**Atlantic Food Bars**  
Your **HOT & COLD** Food Equipment Specialist !  
888-MEAL-SOLUTIONS (888-632-5765)  
[www.atlanticfoodbars.com](http://www.atlanticfoodbars.com)

# Island Express PLUS™

## Wide Three Tier Island Rotisserie Chicken & Hot Packaged Food Merchandiser with 3 Hot Shelves

IP # IMN7245-AS-BP3-LB

6'-2" L x 47" D x 66 1/4" H

**45" Wide Unit**

Details per sign off on page 1 and specifications on last page

Approval signature: \_\_\_\_\_

Date: \_\_\_\_\_

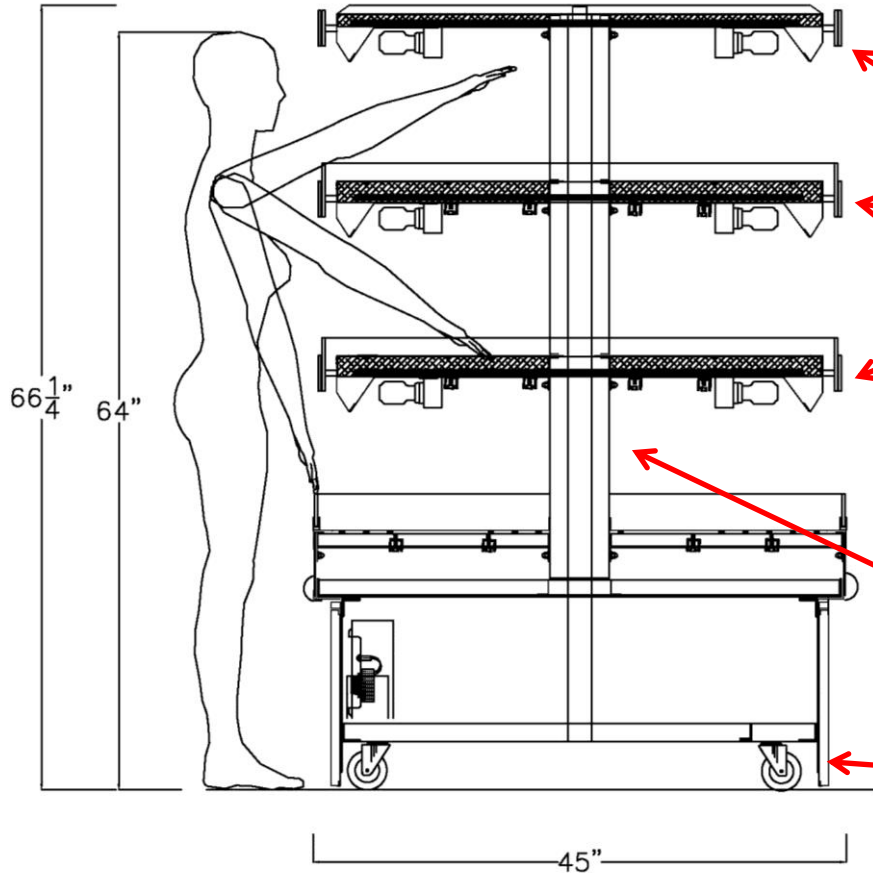

Safety shields and sign track on all 3 levels

Columns to have extra support

Case to be mounted on heavy duty locking casters

Large Chicken Dome Layout

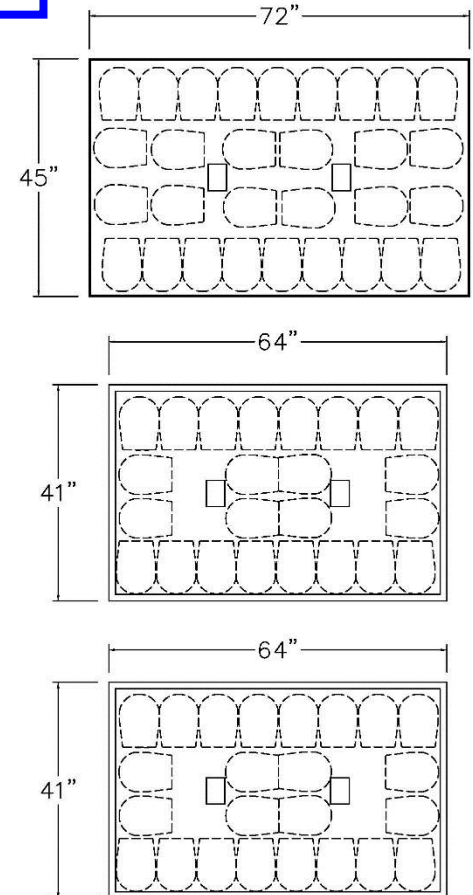

Internal Part #	Custom Description	Dimensions	Voltage	Amps 3 Ph	Chicken Capacity
IMN7245-AS-BP3-LB	6' Three Tier Island Hot Packaged Food Merchandiser	6'-2" L x 47" D x 66-1/4" H	120/208	48.0	78
Requires 60-amp circuit					



**Atlantic Food Bars**  
Your **HOT & COLD** Food Equipment Specialist!  
888-MEAL-SOLUTIONS (888-632-5765)  
[www.atlanticfoodbars.com](http://www.atlanticfoodbars.com)