

Island Express™

Two Tier Island Rotisserie Chicken & Hot Packaged Food Merchandiser

IP #IMN7232-BP3-UO

6'-2" L x 34" D x 63" H

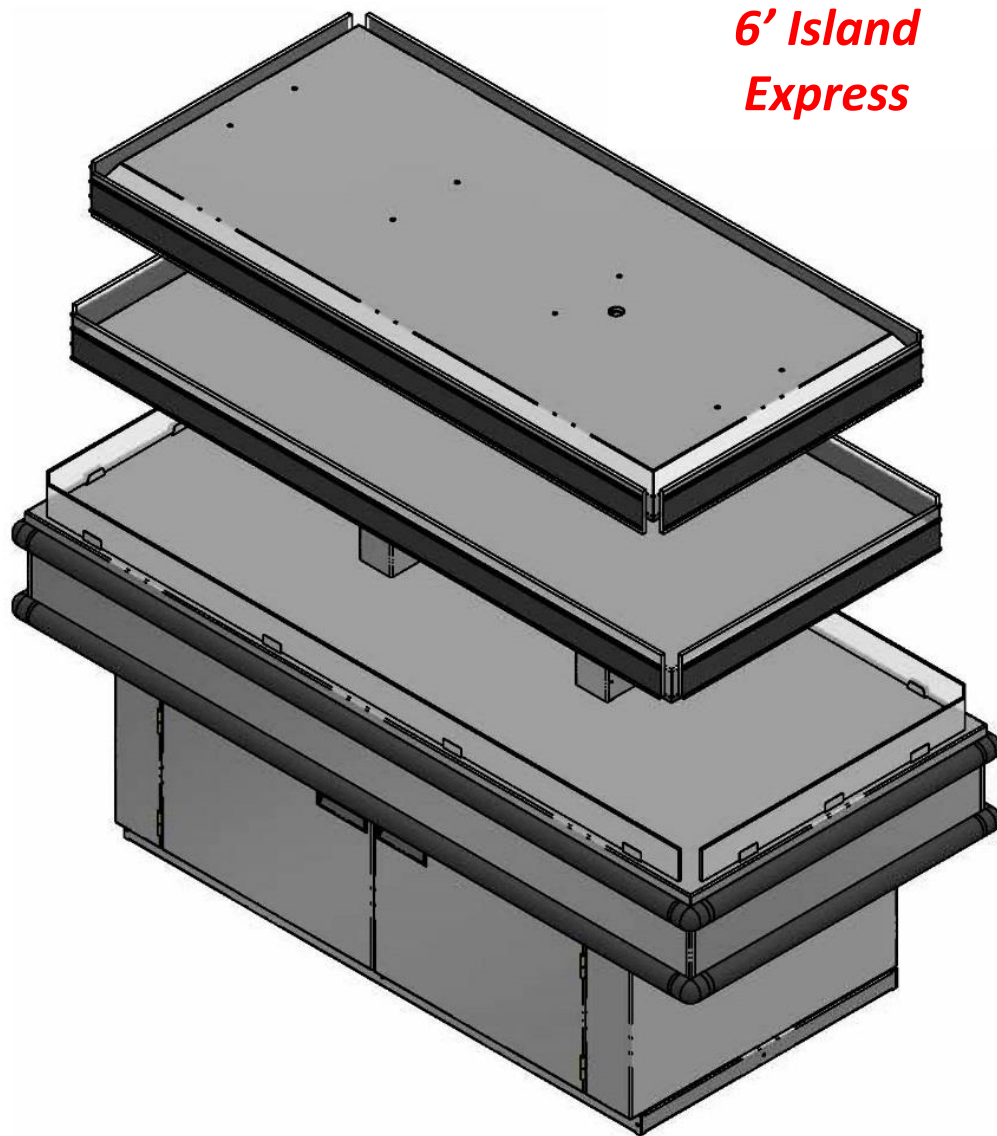

**6' Island
Express**

Approval – Complete All Sections

Colors:

Body: stainless steel

Bumper: black

Electric:

Voltage 120/208V

Phase: Three

Delivery

Site: Loading Dock ___ Ground Level ___

Delivery hours: _____

Depth of case is 34" which will fit through narrowest space between delivery point and install location. Yes ___ No ___ If no – CALL US ASAP

Approval signature: _____

Date: _____

See last page for specifications table – your signature above verifies the installation site has the required power as shown

**SCROLL DOWN
FOR ADDITIONAL VIEWS**



HOT

Atlantic Food Bars
Hot Food Merchandising
Equipment Specialists

888-MEAL-SOLUTIONS (888-632-5765)
www.atlanticfoodbars.com

Island Express™

Two Tier Island Rotisserie Chicken & Hot Packaged Food Merchandiser

IP #IMN7232-BP3-UO
 6'-2" L x 34" D x 63" H

Details per sign off on page 1 and specifications on last page

Approval signature: _____

Date: _____

Plan View –
Chicken Done Capacity

Top Deck

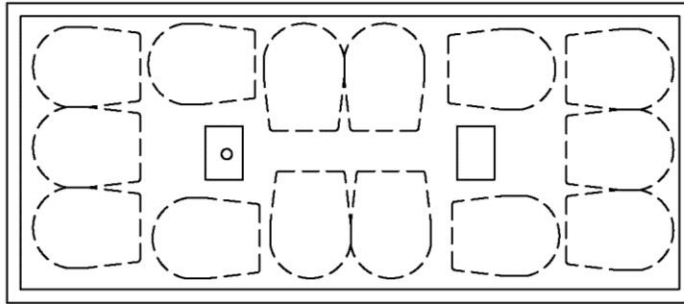

Bottom Deck

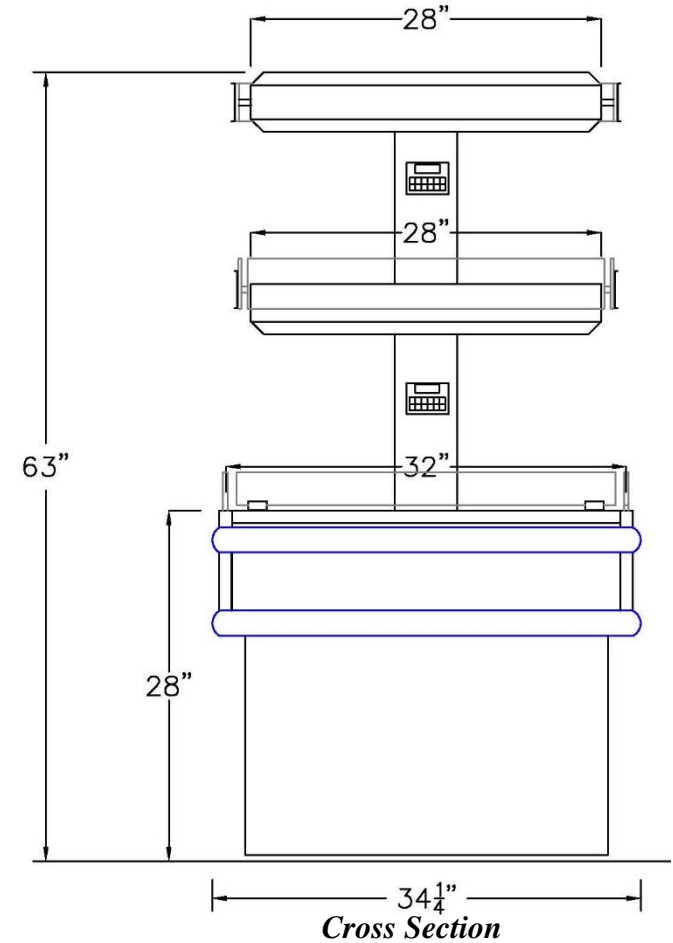
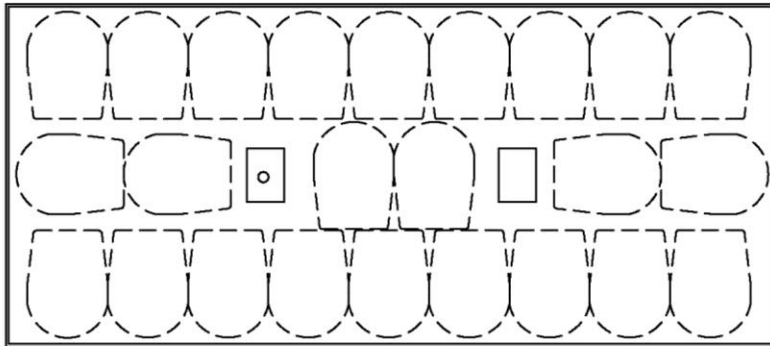

IP CODE	DIMENSIONS L" X W" X H"	CAPACITY	ELECTRICAL			
		LEVELS	VOLTAGE	AMPS	PLUG	MCA
IMN7232-BP3-UO	74.5 x 34.375 x 63	2	120/208	20.5 - 3Ø	-	25.6



Atlantic Food Bars
 Hot Food Merchandising
 Equipment Specialists

888-MEAL-SOLUTIONS (888-632-5765)
www.atlanticfoodbars.com