

**Build your hot food sales & profits
with our IMN Series *Island Express*™ &
Island Express PLUS™ Two & Three Level
Rotisserie Chicken & Hot Packaged Food
Merchandiser**



With plug & play convenience, a full range of sizes and capacities at an affordable cost make this an ideal vehicle to either start a hot grab & go program or expand your existing hot packaged food program. Start with one unit and add more as your business grows, or as you add food product categories. Based upon hourly and daily traffic patterns, you can tailor how many levels are in use to maximize merchandising impact, while controlling shrink, utilizing infinite temperature control for each individual hot deck.

This two or three level case is ideal, not just for rotisserie chicken, but for all packaged foods – turn off the heat on a lower level to merchandise dry goods for cross merchandising impulse sales opportunities. If you are selling hot food full-service, you won't believe the profitability of this self-service unit due to reduced labor costs, convenience for shoppers, higher sales and lower shrink.

**This unit is a MONEY MAKER
and a SELL-THROUGH BEAST !**



**IMN Series Two & Three Level Rotisserie
Chicken & Hot Packaged Food Merchandiser**



Hot
Atlantic Food Bars
Hot & Cold Food Equipment Specialists

888-MEAL-SOLUTIONS (888-632-5765)

info@atlanticfoodbars.com

www.atlanticfoodbars.com



IMN Series Island Express™

Two & Three Level Hot Grab & Go Merchandiser



IMN4832 4' Two-Level
Unit Shown with
Powder Coated Finish

Standard Features

- Two hot levels offer increased merchandising in any footprint
- All stainless-steel exterior body finish
- SAFETY shields on EVERY level protects shoppers, especially curious young shoppers
- Flat, seamless stainless-steel heated decks are care-free and easy to clean
- Atlantic's exclusive combination top heat and light system provides full coverage heat and brilliant illumination for each level
- Includes the industry's most reliable and maintenance-free deck heating system
- Available in more sizes than all of our competitors COMBINED ! Choose the size that meets your store needs

- Accurate digital thermometers provide easy to see readout for each level
- User friendly control package with infinite temperature controls for each deck and dimmer switches for top heat and lighting
- Easily accessible controls located in base behind hinged access doors – keeps kids from touching
- 3" price tag molding provided on all four sides for each heated level
- Single phase breaker panel
- Electric feed through top of case
- Industry's longest warranty – 2 years parts & labor



IMN6032-AS 5' Three-Level
Unit Shown with Stainless
Steel Finish

Options

- Additional merchandising deck – for 3 hot levels in total
- Second row of protective bumper
- 45" wide model for additional capacity
- Laminated steel base in lieu of stainless steel
- Powder coated finish
- Three phase breaker panel



HOT
Atlantic Food Bars
Hot & Cold Food Equipment Specialists
888-MEAL-SOLUTIONS (888-632-5765)
info@atlanticfoodbars.com www.atlanticfoodbars.com



IMN Series Island Express™

Two-Level Hot Grab & Go Merchandiser

2 Levels

Atlantic *HOT* Food Bars IMN Series Two-Level Hot Food Grab & Go Merchandisers are covered by our **INDUSTRY'S LONGEST WARRANTY – 2-year parts and labor.** Warranty does not cover glass breakage or heat lamps, or abuse / misuse by operator. It is our company's policy and mission to continually improve our products, consequently, Atlantic Food Bars reserves the rights to change materials and specifications without notice.

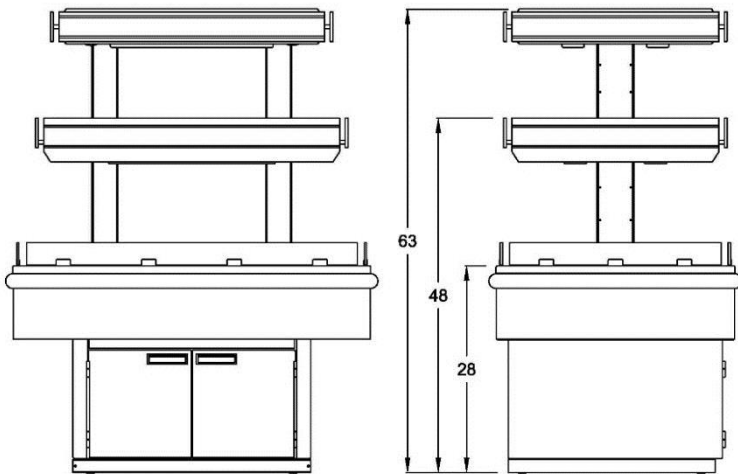
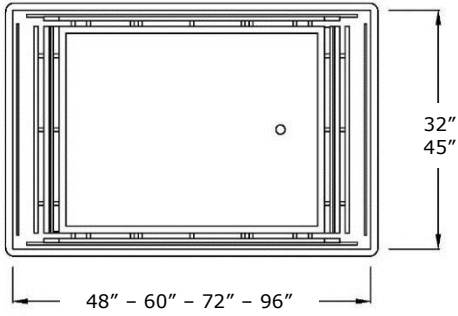

IMN4832 4' Model Shown
with Powder Coated Finish

IP Code	O.A. Dimensions L" x W" x H"	Capacity - Chicken Domes	Electrical
			Voltage
IMN4832	48" x 32" x 63"	23	120/208
IMN6032	60" x 32" x 63"	31	120/208
IMN6045	60" x 45" x 63"	46	120/208
IMN7232	72" x 32" x 63"	38	120/208
IMN7245	72" x 45" x 63"	54	120/208
IMN9632	96 " x 32" x 63"	46	120/208
IMN9645	96" x 45" x 63"	64	120/208



Atlantic Food Bars
Hot & Cold Food Equipment Specialists

888-MEAL-SOLUTIONS (888-632-5765)

info@atlanticfoodbars.com www.atlanticfoodbars.com



Three-Level Hot Grab & Go Merchandiser

Atlantic HOT Food Bars IMN-AS Series Three-Level Hot Food Grab & Go Merchandisers are covered by our **INDUSTRY'S LONGEST WARRANTY – 2-year parts and labor.**

Warranty does not cover glass breakage or heat lamps, or abuse / misuse by operator. It is our company's policy and mission to continually improve our products, consequently, Atlantic Food Bars reserves the rights to change materials and specifications without notice.

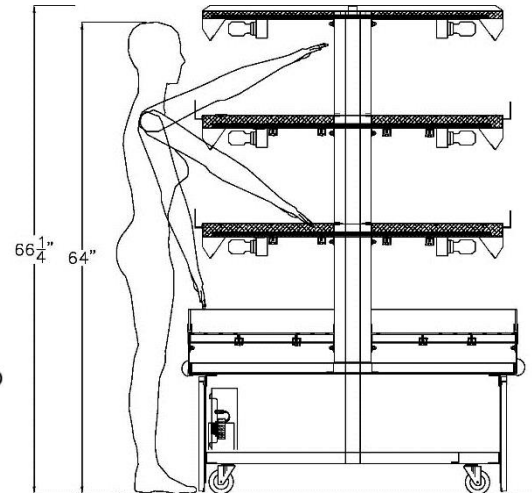
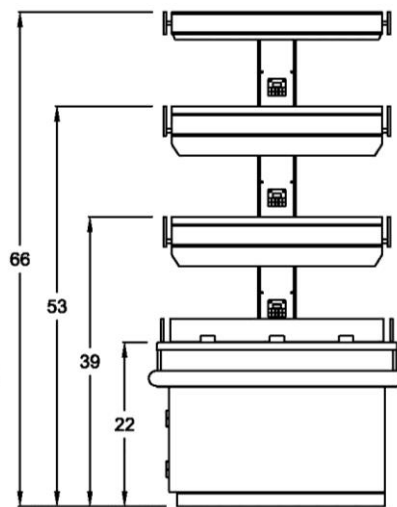
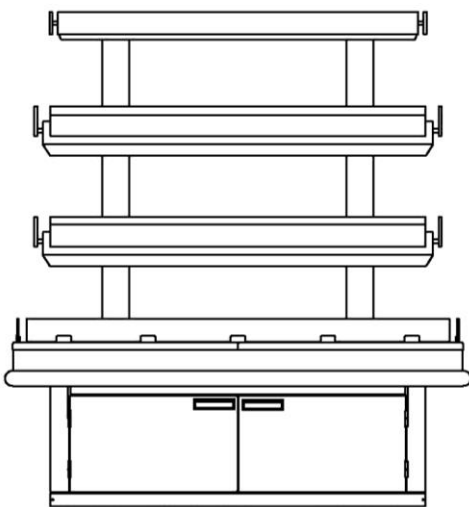
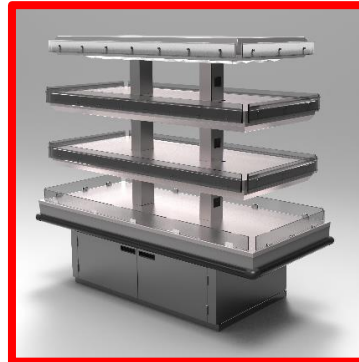
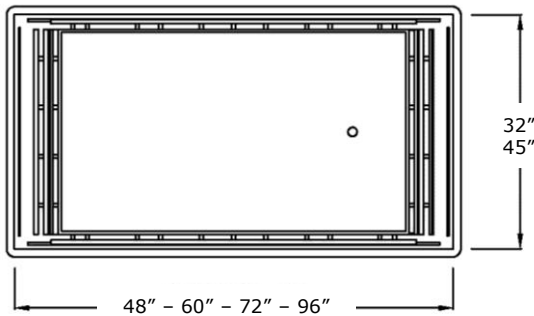

IMN6045-AS WIDE Model Shown

IP Code	O.A. Dimensions L" x W" x H"	Capacity - Chicken Domes	Electrical
			Voltage
IMN4832-AS	48" x 34" x 66"	27	120/208
IMN6032-AS	60" x 34" x 66"	43	120/208
IMN6045-AS	60" x 45" x 66"	66	120/208
IMN7232-AS	72" x 34" x 66"	52	120/208
IMN7245-AS	72" x 45" x 66"	75	120/208
IMN9232-AS	96" x 34" x 66"	70	120/208
IMN9645-AS	96" x 45" x 66"	93	120/208



HOT
Atlantic Food Bars
Hot & Cold Food Equipment Specialists

888-MEAL-SOLUTIONS (888-632-5765)

info@atlanticfoodbars.com www.atlanticfoodbars.com



Atlantic **HOT** Food Bars offers the **MOST** features & options - create the perfect hot case for your food service operation !

OPTIONAL 3" HOT MERCHANDISING DECK

Increase your merchandising impact in the same footprint - no additional floor space required to boost your selling capacity! Height only increases by 3", so maintaining accessibility is not a problem for your shoppers.



STAINLESS STEEL, POWDER COATED OR LAMINATED BASE

Available in any color of your choice ! Match your store décor package or make the case stand out like a traffic light !

WIDE MODEL

Have lots of traffic and lots to sell? Maximize your capacity with our 45" wide model!

SAFETY SHIELD ON EVERY LEVEL

Protect your shoppers (especially those curious young ones) with safety shields on every level of your hot case.

3" PRICE TAG MOLDING ON ALL 4 SIDES

Custom sign package included to help you sell-through your offerings with clear labeling from every angle of visibility!

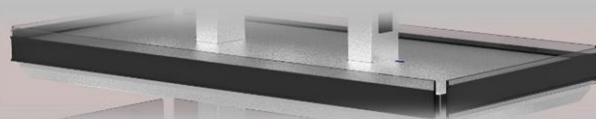

INFINITE HEAT CONTROLS – EACH LEVEL

Easily monitor and manage the heat on each level INDIVIDUALLY with controls hidden behind the base hinged access doors so that you can sell different products at different heats on different shelves. Or, turn off the heat on any given shelf to display dry goods! Digital solar thermometers included for each hot deck.

Features & Options

IMN Series



HOT
Atlantic Food Bars
Hot & Cold Food Equipment Specialists

888-MEAL-SOLUTIONS (888-632-5765)

info@atlanticfoodbars.com www.atlanticfoodbars.com

