

8' Four-Tier Hot Chicken Merchandiser

Low Profile Hot Packaged Food Merchandiser

IP #WRGCL9637-AS-SRM-UO

8'-0" L x 38" D x 54" H

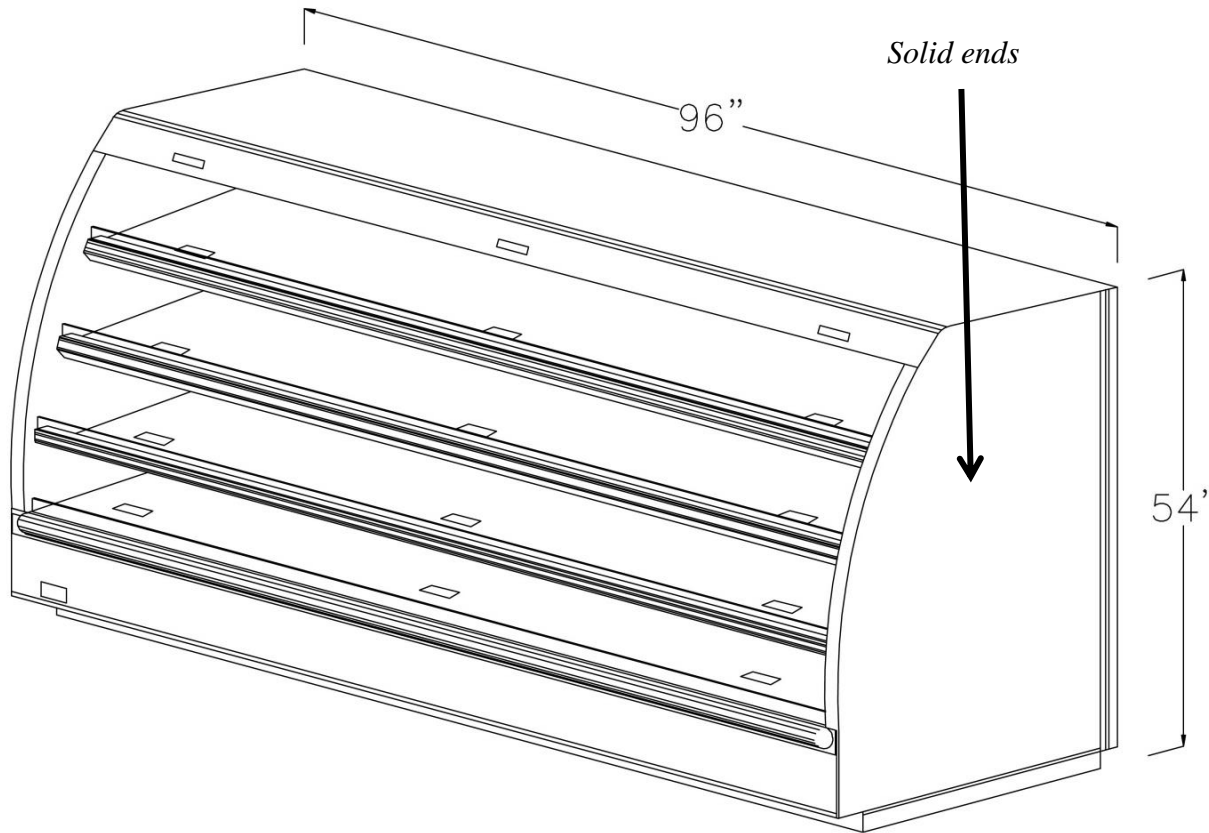

Scroll down for more views

Approval – Complete All Sections

Colors:

Body: Stainless Steel

Bumper: Black

Electric:

Voltage: 120/208V

Phase: Three

Source: Floor

Delivery

Site: Loading Dock Ground Level

Delivery hours: _____

Depth of case is 38" which will fit through narrowest space between delivery point and install location. Yes No If no – CALL US ASAP

Approval signature: _____

Date: _____

See last page for specifications table – your signature above verifies the installation site has the required power as shown



HOT
Atlantic Food Bars
Hot Food Merchandising
Equipment Specialists

888-MEAL-SOLUTIONS

(888-632-5765)

www.atlanticfoodbars.com

4-Tier Hot Chicken Merchandiser

Low Profile Hot Packaged Food Merchandiser

IP #WRGCL9637-AS-SRM-UO

8'-0" L x 38" D x 54" H

Details per sign off on page 1 and specifications on last page

Approval signature: _____

Date: _____

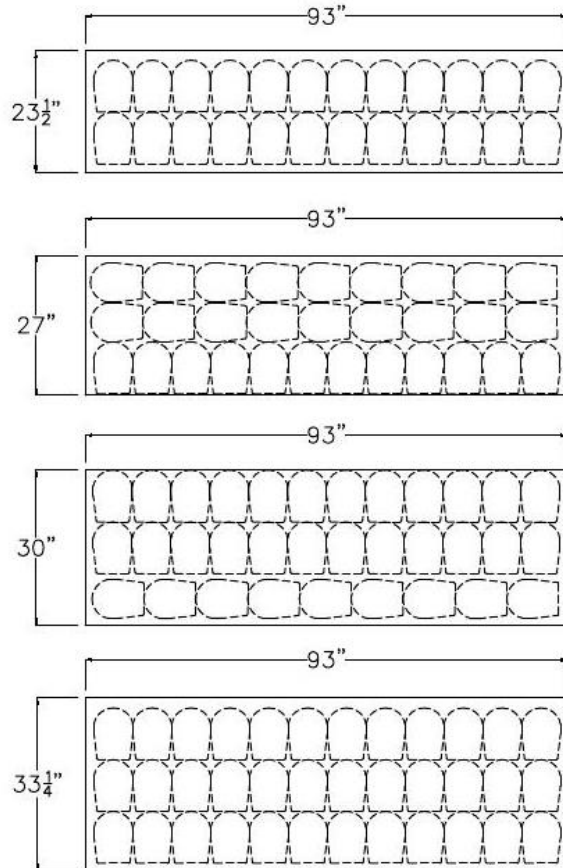

Chicken Dome Capacity

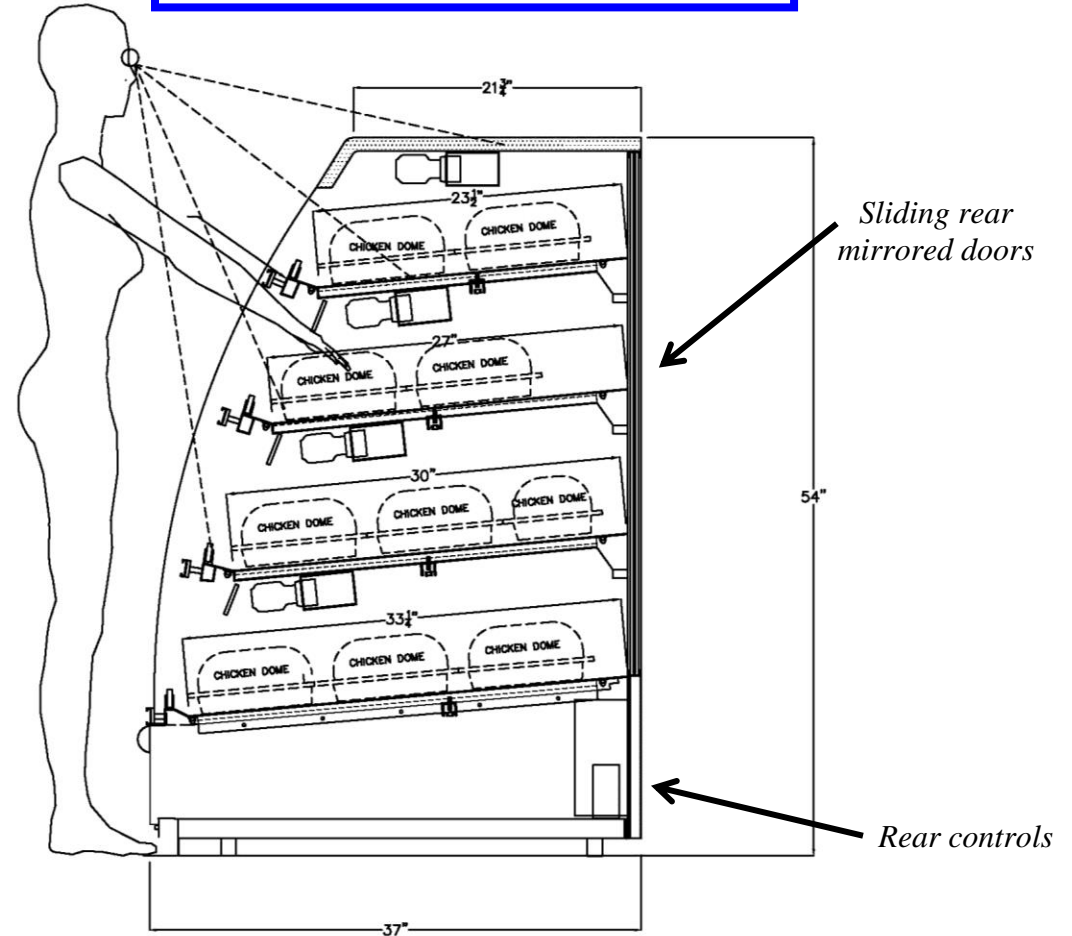

Cross Section

Internal Part #	Custom Description	Dimensions	Voltage	Amps 3 Ph	Rotisserie Dome Capacity
WRGCL9637-AS-SRM-UO	8' Four-Tier Hot Packaged Food Merchandiser	8'-0" L x 38" D x 54" H	120/208	39.7	123

Atlantic Food Bars
Hot Food Merchandising
Equipment Specialists

888-MEAL-SOLUTIONS (888-632-5765)
www.atlanticfoodbars.com

End Cap 6 Well Soup Bar

IP #SW6036-AW3-FMC-ISW6-NPD-SCLD32-UO

60" L x 37" D x 34" H (Counter)

Shown with FRONT controls, napkin dispenser, spoon bin, 3 each built in cup dispensers and 2 each lid bins in slanted front panel

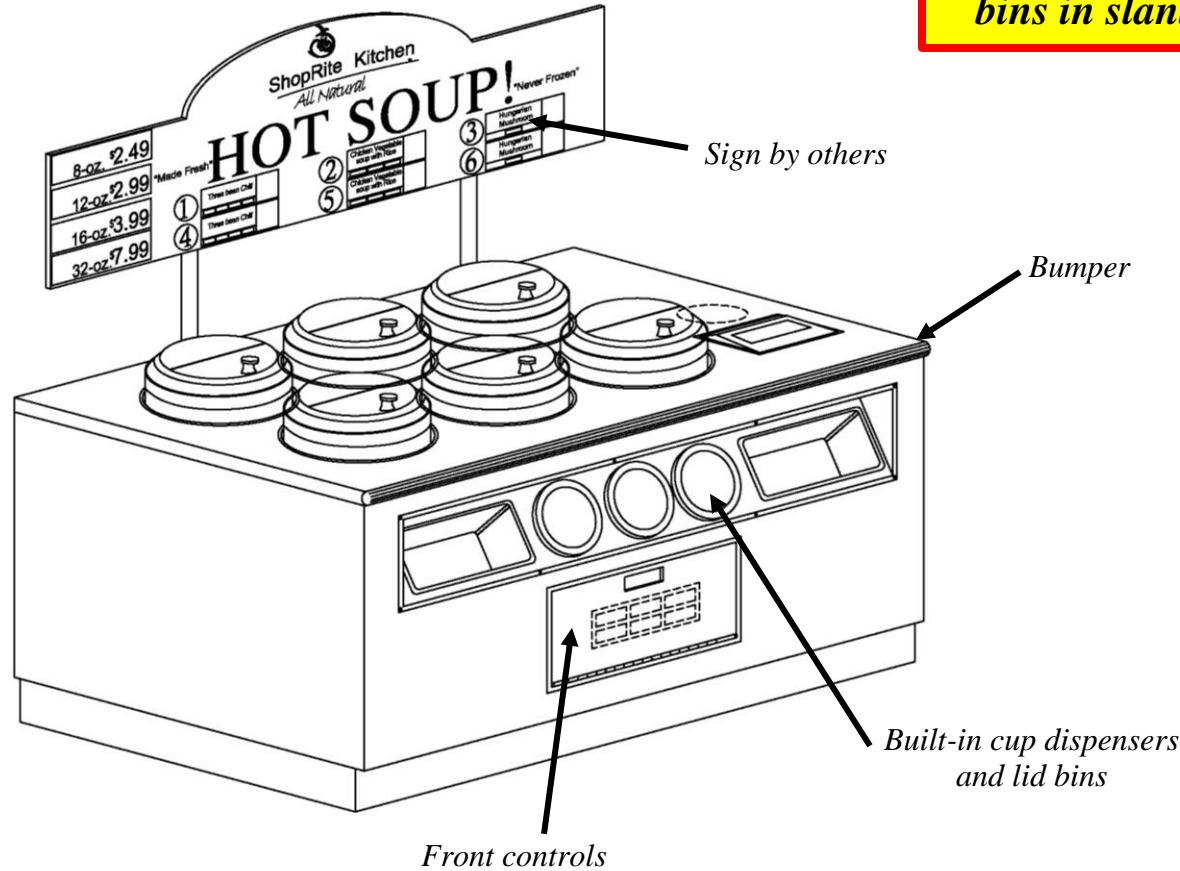

Approval – Complete All Sections

Colors:

Body: Stainless Steel
Bumper: Black
Countertop: Stainless Steel

Electric:

Voltage: 120V
Phase: Single
Source: Floor

Delivery

Site: Loading Dock Ground Level

Delivery hours:

Depth of case is 37" which will fit through narrowest space between delivery point and install location. Yes No If no – CALL US ASAP

Approval signature:

Date:

See last page for specifications table – your signature above verifies the installation site has the required power as shown

**SCROLL DOWN –
PAGES 2-3 HAVE
ADDITIONAL VIEWS**



Atlantic SOUP Bars
Soup Merchandising
Equipment Specialists

888-MEAL-SOLUTIONS
(888-632-5765)
www.atlanticfoodbars.com

End Cap 6 Well Soup Bar

IP #SW6036-AW3-FMC-ISW6-NPD-SCLD32-UO
60" L x 37" D x 34" H (Counter)

Details per sign off on page 1 and specifications on last page

Approval signature: _____

Date: _____

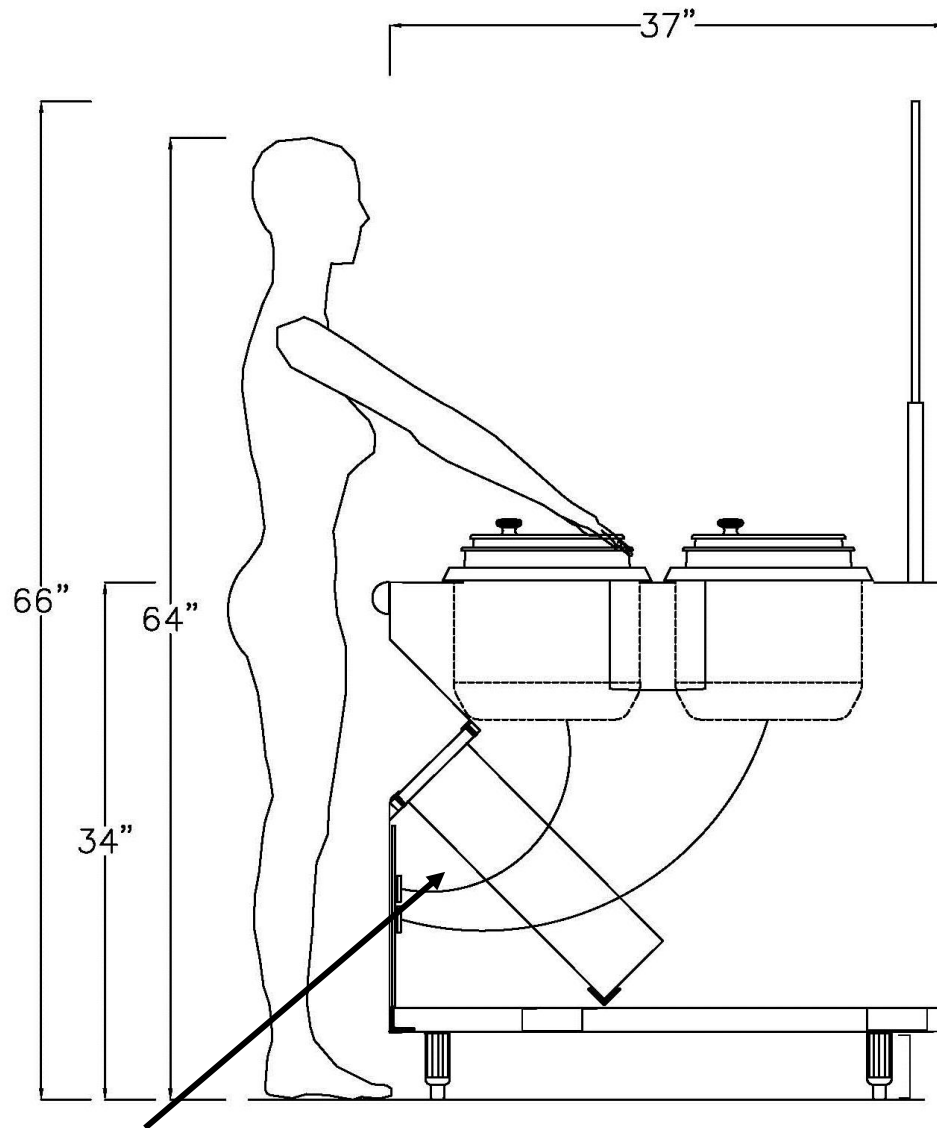

Front controls

Cross Section

Shown with FRONT controls, napkin dispenser, spoon bin, 3 each built in cup dispensers and 2 each lid bins in slanted front panel

**SCROLL DOWN –
PAGE 3 HAS
ADDITIONAL VIEWS**

**Celebrating 70
Years in 2017!**



Atlantic *goup* Bars
**Soup Merchandising
Equipment Specialists**

888-MEAL-SOLUTIONS (888-632-5765)
www.atlanticfoodbars.com

End Cap 6 Well Soup Bar

IP #SW6036-AW3-FMC-ISW6-NPD-SCLD32-UO
60" L x 37" D x 34" H (Counter)

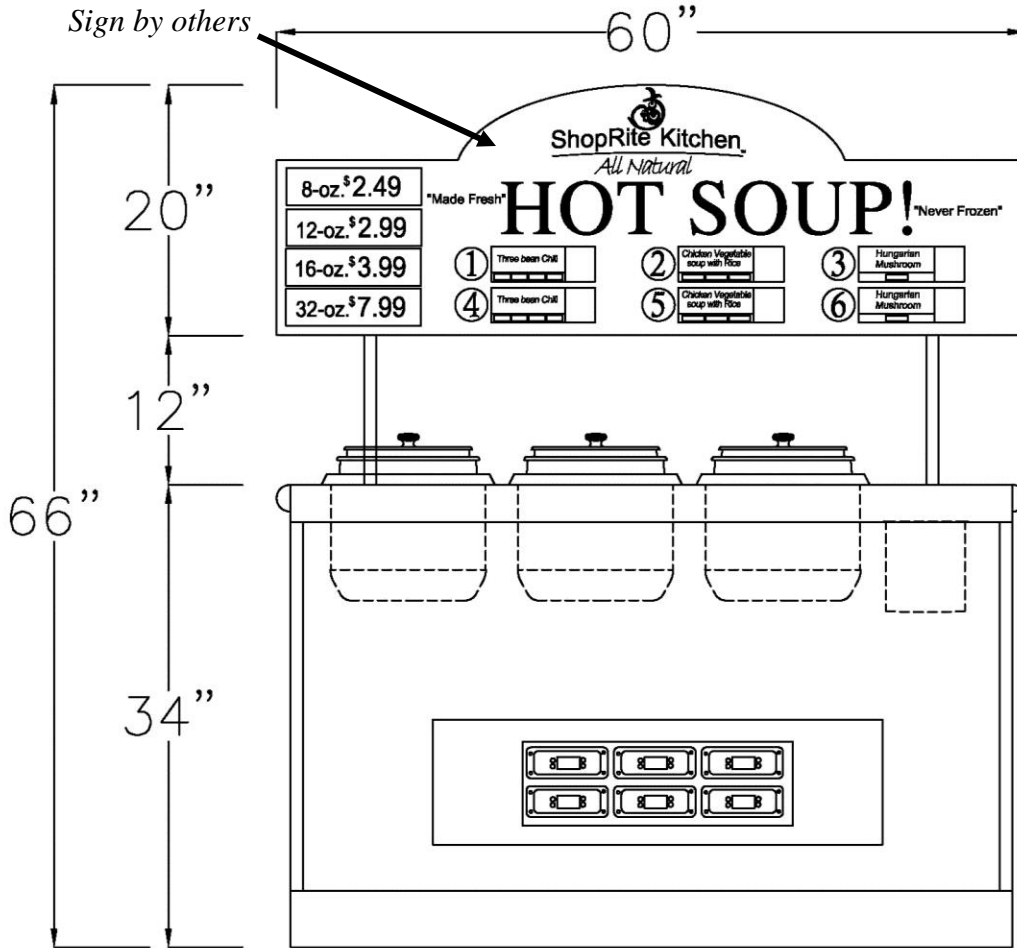

Front Elevation

Shown with FRONT controls, napkin dispenser, spoon bin, 3 each built in cup dispensers and 2 each lid bins in slanted front

Details per sign off on page 1 and specifications on last page
Approval signature: _____
Date: _____

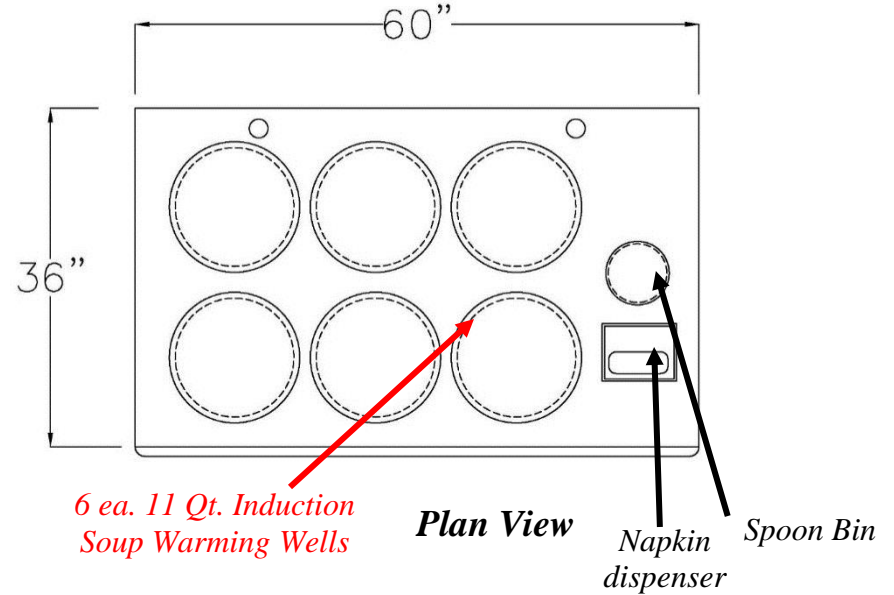

6 ea. 11 Qt. Induction Soup Warming Wells

Plan View

Napkin dispenser Spoon Bin

Internal Part #	Custom Description	Dimensions	Voltage	Amps 1 Ph	11-qt Soup Well Capacity
SW6036-AW3-FMC-ISW6-NPD-SCLD32-UO	5' Six-Well Soup Bar	60" L x 37" D x 34" H	120	12.5	6

Maximum overcurrent protection = 20 amps



Atlantic SOUP Bars
Soup Merchandising
Equipment Specialists

888-MEAL-SOLUTIONS (888-632-5765)
www.atlanticfoodbars.com