

Make your Hot Grab & Go Food offerings a self service profit center anywhere in your store with our HHTD Series Three-Level Mobile Hot Grab & Go Merchandiser !

3 Tier

With three hot levels, you can increase your offering, create more impulse sales, and grow your hot food program in a tiny footprint. Based upon hourly and daily traffic patterns, you can utilize infinite temperature control for each individual hot deck, controlling shrink, while maximizing merchandising impact.



This three level case is ideal, not just for rotisserie chicken, but for all packaged foods – turn off the heat on lower levels during slower sales periods to merchandise dry goods – reduce shrink AND build sales even during low traffic periods.. If you are selling hot food full service, you won't believe the profitability of this self service unit due to reduced labor costs, convenience for shoppers, higher sales and lower shrink.

This unit is a MONEY MAKER and a SELL-THROUGH BEAST !

HHTD Series Three-Level Mobile Hot Food / Rotisserie Chicken Grab & Go Merchandiser



Atlantic Food Bars
Hot & Cold Food Equipment Specialists
 888-MEAL-SOLUTIONS (888-632-5765)

info@atlanticfoodbars.com www.atlanticfoodbars.com



HHTD Series

Three-Level Mobile Hot Food / Rotisserie Chicken Grab & Go Merchandiser



Standard Features

- Triple deck design offers more capacity in a small footprint, as well as cross merchandising opportunities
- Attractive and durable stainless steel finish
- Tempered glass end panels provide exceptional product exposure with no plastic to scratch, craze or crack
- Brilliant LED lighting system illuminates evenly and builds profitable, incremental impulse sales
- High output heat element in deck provides consistent heat and unmatched reliability
- Adjustable temperature control for the heated decks and dimmer switch for top heat and lighting

- Easy accessible controls located in base behind access door
- Digital thermostat and thermometer on each level
- Heavy duty locking casters
- Complete with cord and plug
- 3" PTM on each side of case
- Arrives fully assembled – unwrap, plug in and start selling!

Options

- Entire body to be powder coated steel in lieu of stainless steel
- Rotisserie chicken photos
- Wood bread baskets
- Single phase breaker panel
- Three phase breaker panel
- Electric feed through top of case



HOT
Atlantic Food Bars
Hot & Cold Food Equipment Specialists

888-MEAL-SOLUTIONS (888-632-5765)

info@atlanticfoodbars.com www.atlanticfoodbars.com



HHTD Series

Triple Deck Mobile Hot Food / Rotisserie Chicken Grab & Go Merchandiser

Atlantic Food Bars HHTD Series Mobile Hot Food / Rotisserie Chicken Grab & Go Merchandiser is covered by our INDUSTRY'S LONGEST WARRANTY – 2 year parts and labor. Warranty does not cover glass breakage or heat lamps, or abuse / misuse by operator. In line with its policy to continually improve its products, Atlantic Food Bars reserves the rights to change materials and specifications without notice.

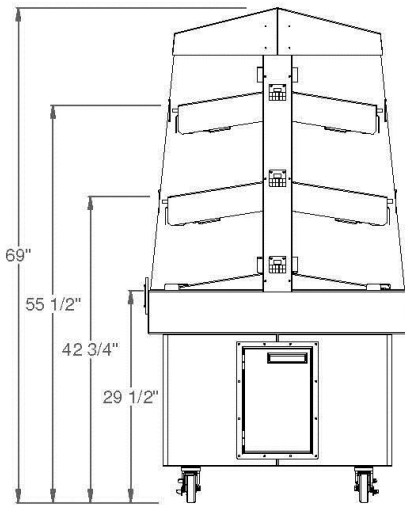
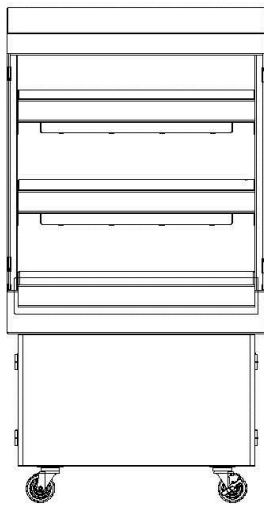
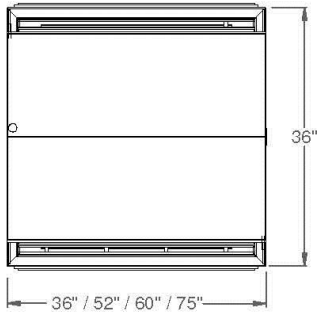

IP Code	O.A. Dimensions L" x W" x H"	Capacity	Voltage
HHTD3636	36" x 36" x 69"	42 Chickens	120/208
HHTD5136	51" x 36" x 69"	60 Chickens	120/208
HHTD6036	60" x 36" x 69"	72 Chickens	120/208
HHTD7436	74" x 36" x 69"	84 Chickens	120/208



HOT
Atlantic Food Bars
Hot & Cold Food Equipment Specialists

888-MEAL-SOLUTIONS (888-632-5765)

info@atlanticfoodbars.com www.atlanticfoodbars.com



Options, accessories and features create the perfect merchandiser for YOUR food service operation!

MAX OUT YOUR MERCHANDISING WITH THREE HOT LEVELS

Increase sales in a compact footprint by going vertical ! This shop-around multi-deck case can offer as much or as little as you desire, in 3' / 4' / 5' / 6' standard or custom configurations.



INFINITE HEAT CONTROL - EACH INDIVIDUAL LEVEL

Control the top AND bottom heat on each tier! Heat lamps and hot decks feature individual temperature control, allowing you to intelligently stock your case and minimize shrink based upon periods of fluctuating demand. Merchandise dry goods on a lower level while selling hot rotisserie chicken and packaged grab & go products on other levels at the same time!



WOOD BREAD BASKETS

Allow your customers to "make it a meal" with additional merchandising display space for dry goods in the same minimal footprint.



CUSTOM SIGN PACKAGE

Three levels of sign track allow for easy, organized display of product signage. Custom sign packages come with every case – fill out our signage form at the time of your order, and your individual labels will be ready to slide right into the price tag molding the moment you receive the merchandiser!

Options & Features

HHTD Series



HOT

Atlantic Food Bars

Hot & Cold Food Equipment Specialists

888-MEAL-SOLUTIONS (888-632-5765)

info@atlanticfoodbars.com

www.atlanticfoodbars.com

