

Mobile Hot Wing Bar

IP# MHFC6044-BP3-UO

5'-0" L x 46" D x 54" H

12/10/19



Approval – Complete All Sections

Colors:

Body: Stainless Steel

Bumper: n/a

Electric:

Voltage: 120/208V

Phase: Three

Source: Ceiling Floor

Delivery

Site: Loading Dock Ground Level

Delivery hours:

Depth of case is 46" which will fit through narrowest space between delivery point and install location. Yes No If no – CALL US ASAP

Approval signature:

Date:

See last page for specifications table – your signature above verifies the installation site has the required power as shown

SCROLL DOWN FOR MORE DETAILS



Atlantic Food Bars
Hot Food Merchandising
Equipment Specialists

HOT

888-MEAL-SOLUTIONS
(888-632-5765)

www.atlanticfoodbars.com

Mobile Hot Wing Bar

IP# MHFC6044-BP3-UO

5'-0" L x 46" D x 54" H

12/10/19

Details per sign off on page 1 and specifications on last page

Approval signature: _____

Date: _____

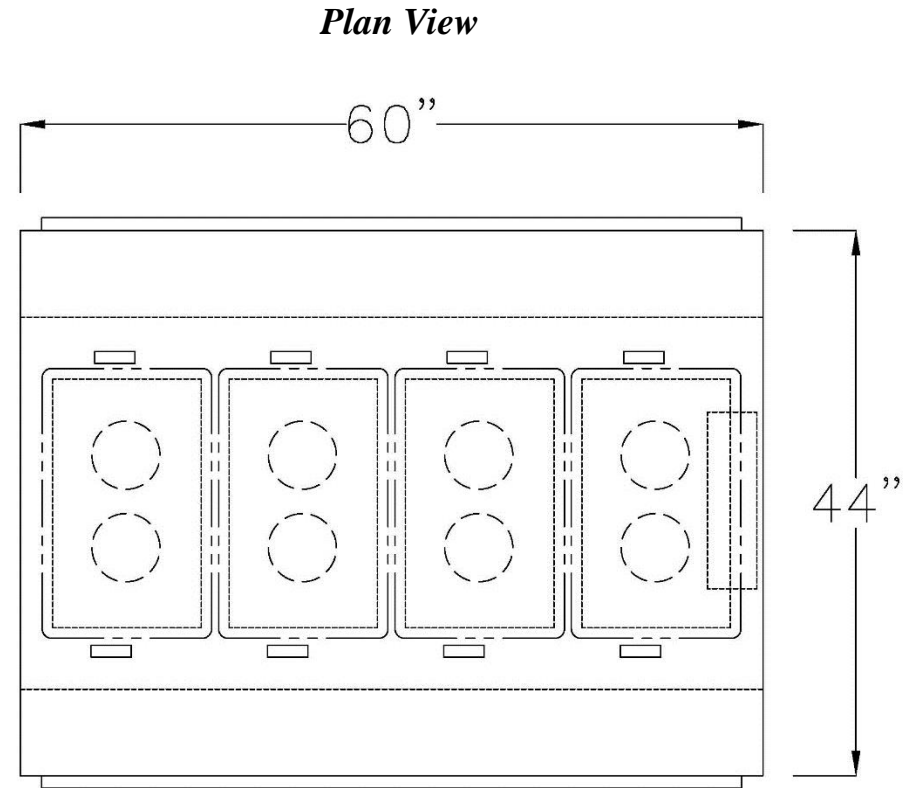
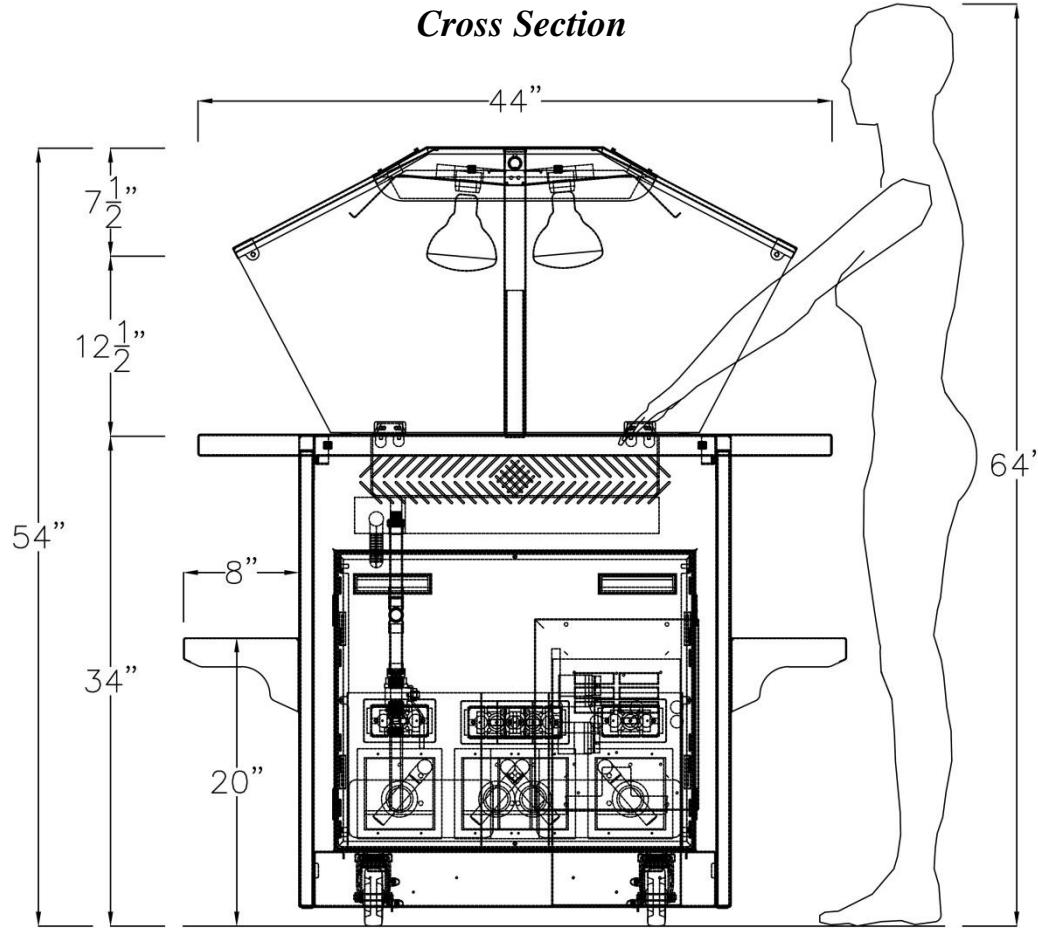

Internal Part #	Custom Description	Dimensions	Voltage	Amps 3 Ph	12" x 20" Pan Openings
MHFC6044-BP3-UO	5' Mobile Hot Wing Bar	5'-0" L x 46" D x 54" H	120/208	20.3	4
Cases come with NEMA #21-30 cord & plug					
Weight of case is approximately 450 lbs					

Celebrating 70 Years in 2017!



Atlantic Food Bars
Hot Food Merchandising
Equipment Specialists

888-MEAL-SOLUTIONS (888-632-5765)
www.atlanticfoodbars.com