

4' Mobile Rotisserie Chicken & Hot Packaged Food Merchandiser

IP #HH5125
4'-3" L x 25" D x 58" H

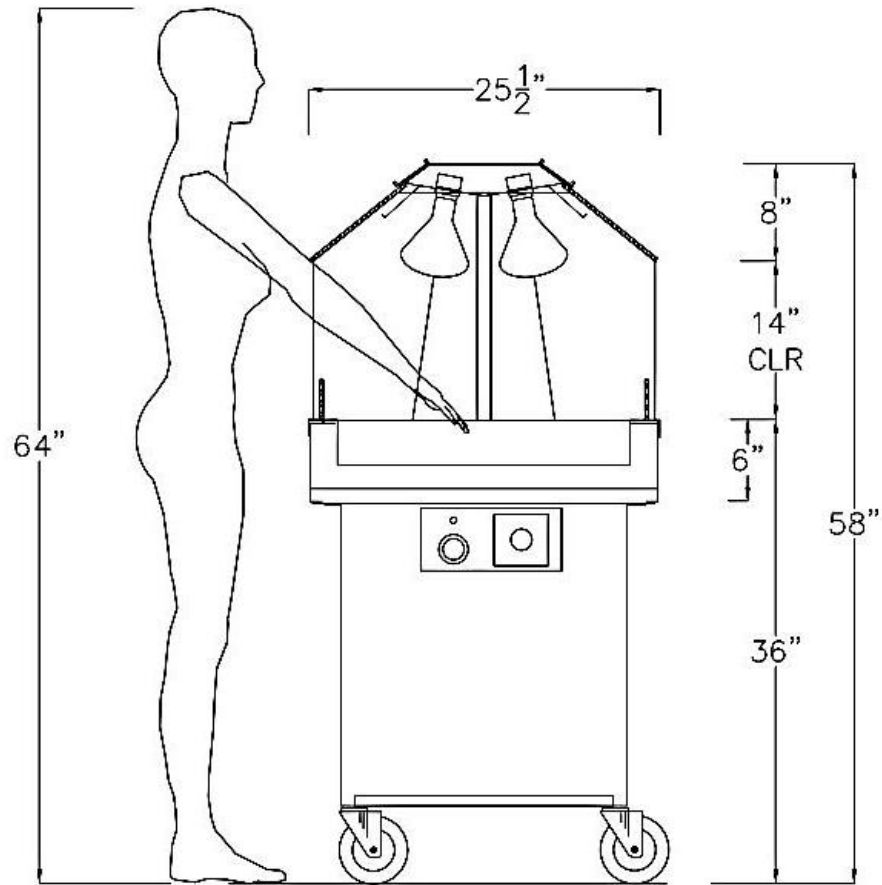

Internal Part #	Custom Description	Dimensions	Voltage	Amps 1 Ph	Chicken Capacity
HH5125	4' Mobile Rotisserie Chicken & Hot Packaged Food Merchandiser	4'-3" L x 25" D x 58" H	120	15.8	24

HOT



Atlantic Food Bars
Hot Food Merchandising
Equipment Specialists

888-MEAL-SOLUTIONS (888-632-5765)
www.atlanticfoodbars.com