

# ***Make your Refrigerated Grab & Go Food offerings a self service profit center by incorporating our MDR Series Multi-Deck Packaged Cold Food Merchandiser !***



## **Standard Features**

- Deck plus 4 adjustable shelves
- Brilliant interior LED lighting
- Sign track on each level
- Slanted or flat shelves offer outstanding product visibility and access
- Super cold self-contained airflow refrigeration system or remote refrigeration system

MDR4835 4' Unit Shown



Create more impulse sales and grow your cold grab & go program! Maximize merchandising impact with optional clear end panels to provide visibility from all angles.

This case is ideal for refrigerated grab & go sandwiches, salads, fruit, sides, and beverages. If you are selling refrigerated food full service, you won't believe the profitability of this self service unit due to reduced labor costs, convenience for shoppers, higher sales and lower shrink.

This unit is a **MONEY MAKER** and a **SELL-THROUGH BEAST !**



## **Atlantic Food Bars**

**Hot & Cold Food Equipment Specialists**

888-MEAL-SOLUTIONS (888-632-5765)

info@atlanticfoodbars.com

www.atlanticfoodbars.com



**MDR Series Multi-Level Refrigerated Grab & Go Packaged Cold Food Merchandiser**

**Options, accessories and features offer you the perfect merchandiser for your food service operation!**



**MAX OUT YOUR MERCHANDISING WITH DECK + THREE OR FOUR SHELVES**

Increase sales in a compact footprint by going vertical! This multi-deck case comes in 3' / 4' / 5' / 6' configurations.

**CLEAR VIEW END PANELS**

Provide clear visibility from all angles with optional clear end panels.



**FINISHES AVAILABLE IN STAINLESS STEEL, LAMINATE OR POWDER COAT**

Have it your way, in any finish.

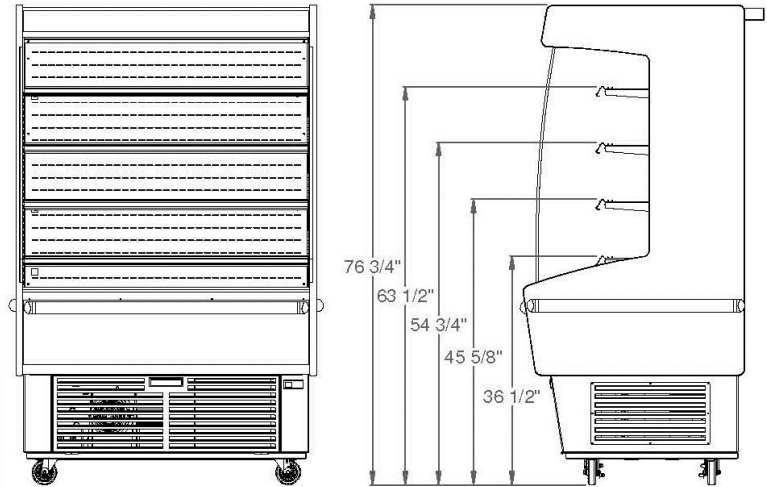
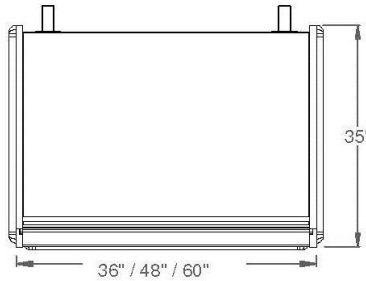

**SIGN TRACK**

Multiple levels of sign track allow for easy, organized display of product signage. Your individual labels will be ready to slide right into the price tag molding the moment you receive the merchandiser!



**ENERGY SAVING LED LIGHTING ON EVERY SHELF**

Brilliant illumination attracts shoppers attention and reduces maintenance and energy costs

**Atlantic Food Bars** MDR Series Multi-Level Refrigerated Multi-Deck Packaged Cold Food Merchandisers are covered by our **INDUSTRY'S LONGEST WARRANTY** – 1 year parts and labor. Warranty does not cover glass breakage, or abuse / misuse by operator. In line with its policy to continually improve its products, Atlantic Food Bars reserves the rights to change materials and specifications without notice.

**MDR Series Options & Features**



**Atlantic Food Bars**  
**Hot & Cold Food Equipment Specialists**  
 888-MEAL-SOLUTIONS (888-632-5765)  
 info@atlanticfoodbars.com    www.atlanticfoodbars.com

