

NARROW Island Salad Bar

With 4 Sided Air Overflow Pan Rail & Tubular Tray Slide

IP #Custom
160" L x 61" W x 54" H

Details per sign off on page 3 and specifications on page 4

Approval signature: _____

Date: _____

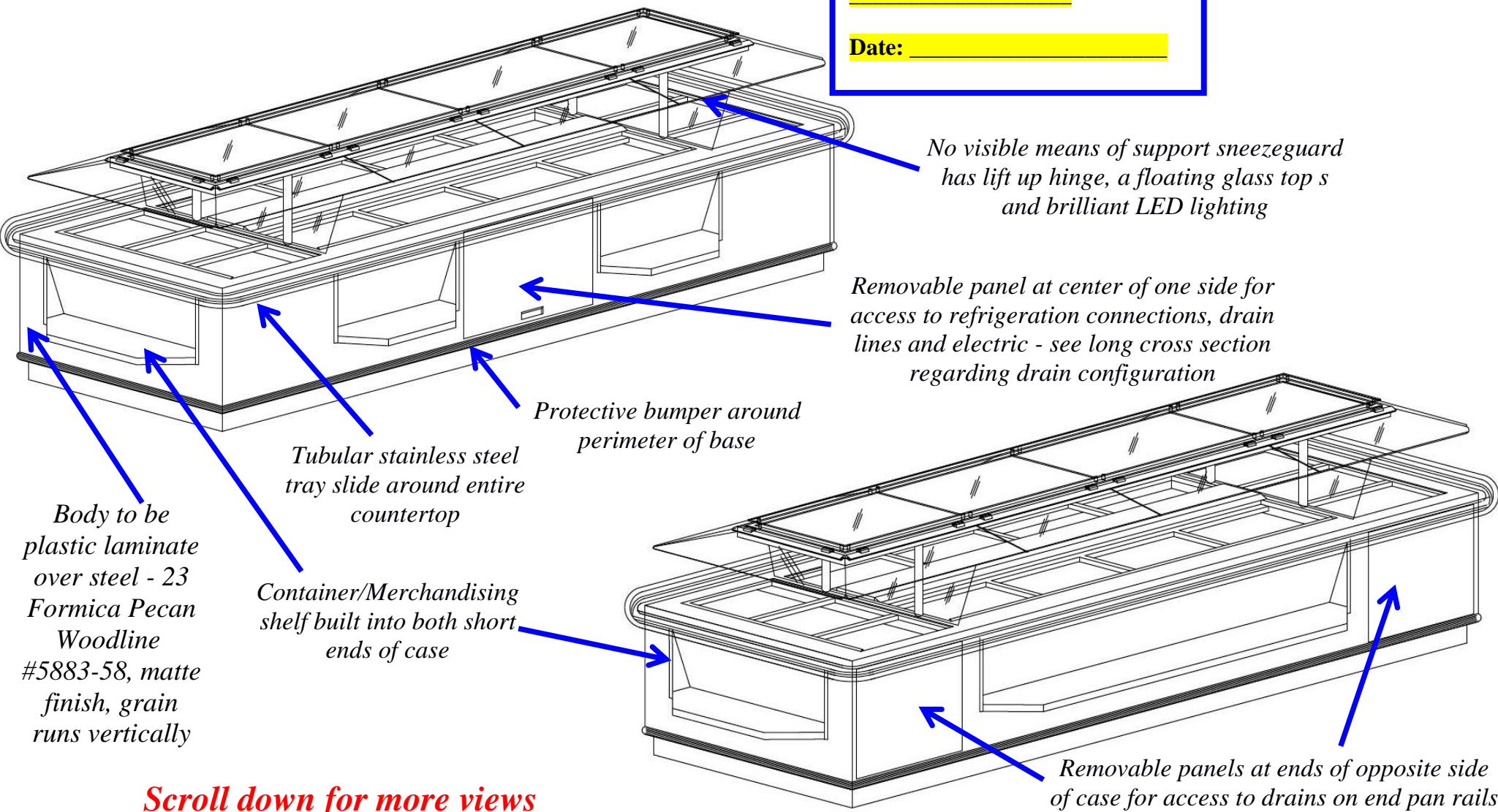

No visible means of support sneezeguard has lift up hinge, a floating glass top s and brilliant LED lighting

Removable panel at center of one side for access to refrigeration connections, drain lines and electric - see long cross section regarding drain configuration

Protective bumper around perimeter of base

Tubular stainless steel tray slide around entire countertop

Container/Merchandising shelf built into both short ends of case

Body to be plastic laminate over steel - 23 Formica Pecan Woodline #5883-58, matte finish, grain runs vertically

Removable panels at ends of opposite side of case for access to drains on end pan rails

Scroll down for more views



Atlantic ^{SALAD} Food Bars
Salad Merchandising
Equipment Specialists

888-MEAL-SOLUTIONS
(888-632-5765)
www.atlanticfoodbars.com

NARROW Island Salad Bar

With 4 Sided Air Overflow Pan Rail & Tubular Tray Slide

IP #Custom

160" L x 61" W x 54" H

Details per sign off on page 3 and specifications on page 4

Approval signature: _____

Date: _____

No visible means of support sneezeguard has lift up hinge, a floating glass top s and brilliant LED lighting

NSF7 air overflow refrigeration system

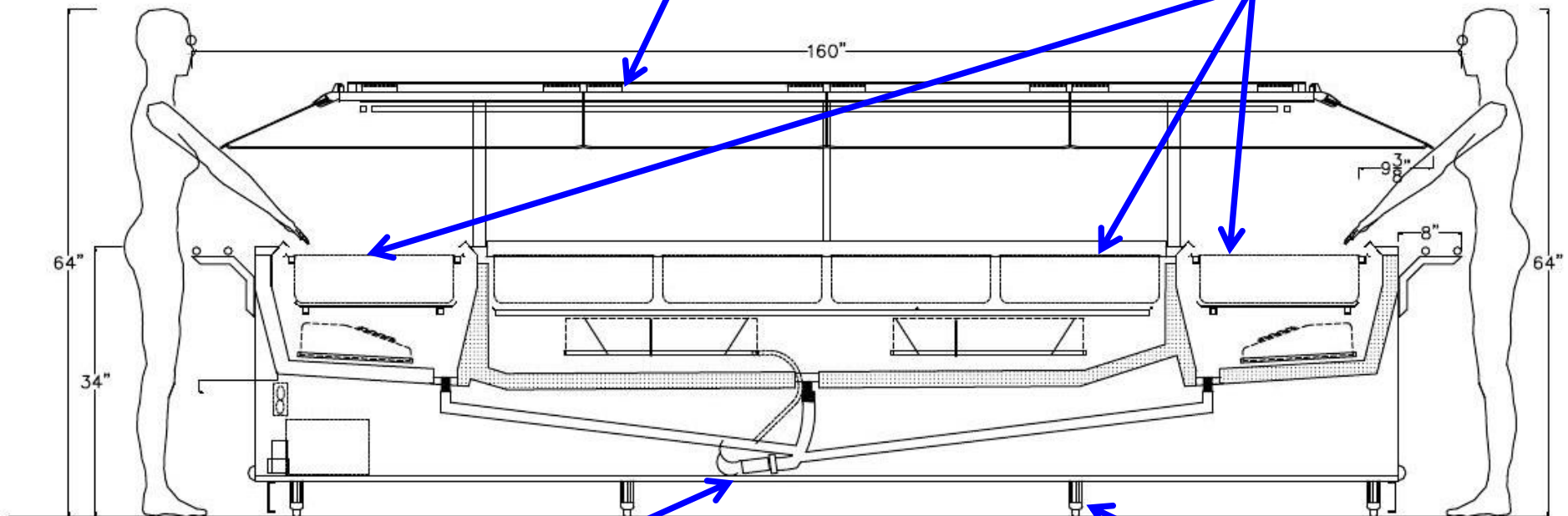

All 3 refrigerated liners drain to outlet in center of case

Long Cross Section

Stainless steel legs with adjustable feet



Atlantic Food Bars
Salad Merchandising
Equipment Specialists

888-MEAL-SOLUTIONS
(888-632-5765)
www.atlanticfoodbars.com

NARROW Island Salad Bar

With 4 Sided Air Overflow Pan Rail & Tubular Tray Slide

IP #Custom

160" L x 61" W x 54" H

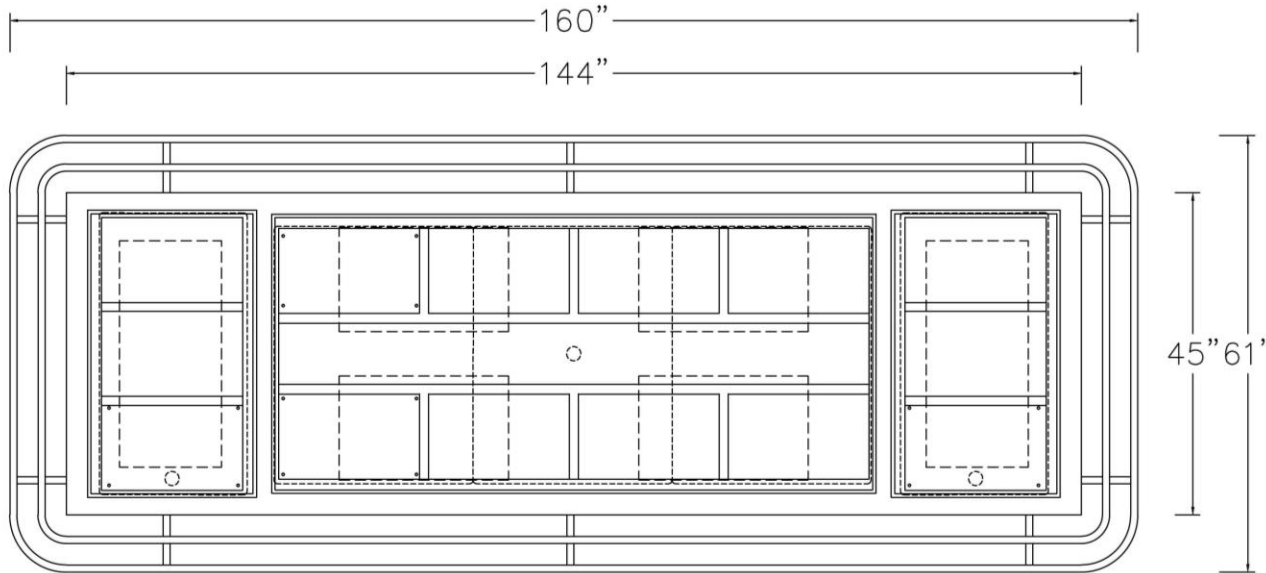

Plan

Hy-Vee # ___ Winterset

Approval – Complete All Sections

Colors:

Body : Laminate: Mfr. P. Lam 23 Formica

Color Pecan Woodline # 5883-58 matte

If wood grain laminate – direction of grain. Vertical

Countertop: #4 Satin finish 304 stainless steel

Sneeze-guard framework : #4 Satin finish stainless steel

Kickplates : #4 satin finish stainless steel

Refrigeration:

Remote Refrigerant _____

Electric:

Voltage 120V

Phase: Single

Source: Floor _____

Delivery

Site: Loading Dock _____ Ground Level _____

Delivery hours: _____

Depth of case is 61" which will fit through narrowest space between delivery point and install location. Yes

_____ No _____ If no – CALL US ASAP

Approval signature: _____



Atlantic Food Bars
Salad Merchandising
Equipment Specialists

888-MEAL-SOLUTIONS
(888-632-5765)
www.atlanticfoodbars.com

NARROW Island Salad Bar

With 4 Sided Air Overflow Pan Rail & Tubular Tray Slide

IP #Custom

160" L x 61" W x 54" H

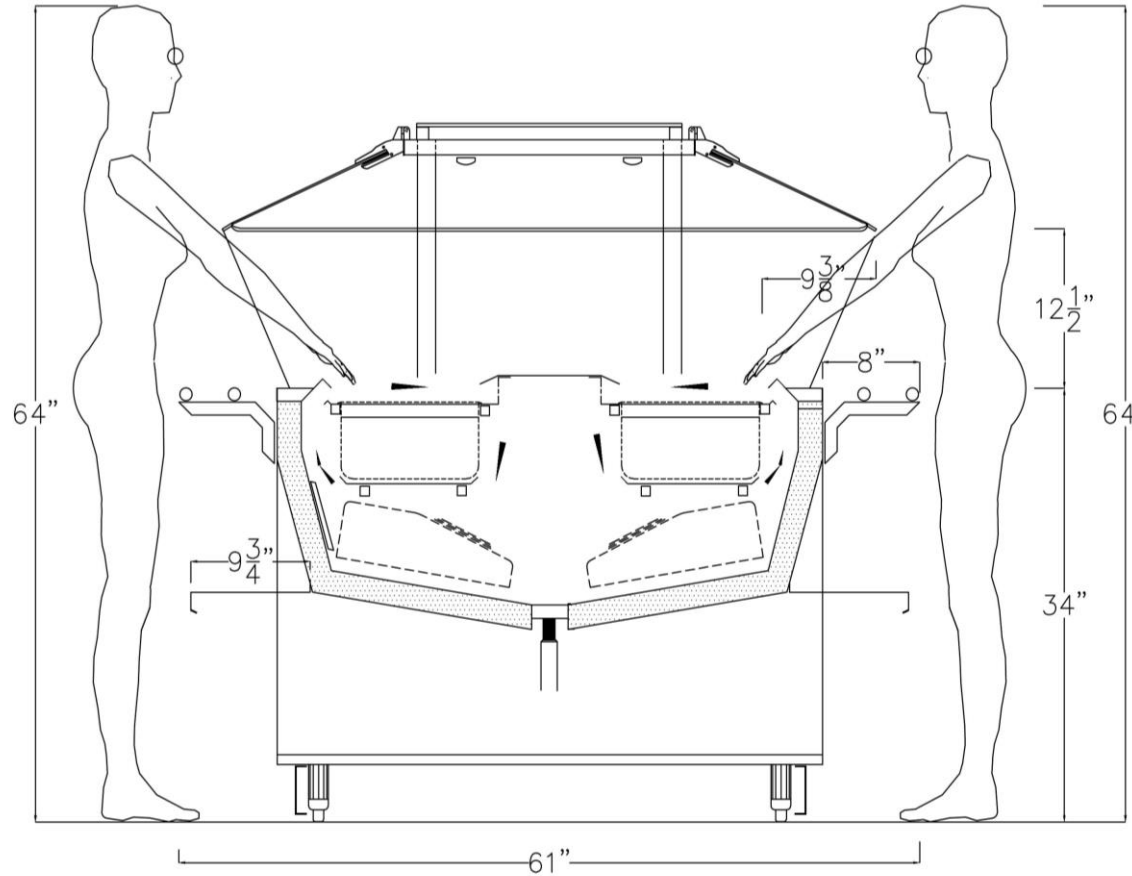

Details per sign off on page 3 and specifications below

Approval signature: _____

Date: _____

Internal Part #	Custom Description	Dimensions	Voltage	Remote Refrigeration	12" x 20" Pan Capacity	BTU
				Amps 1 Ph		
Custom ISBN-SPR-SPR-TS-VH	Narrow Island Salad Bar	144" L x 61" D x 54" H	120	11.2	14	11,400



Atlantic Salad Bars
Salad Merchandising
Equipment Specialists

888-MEAL-SOLUTIONS
 (888-632-5765)
www.atlanticfoodbars.com