

28' Refrigerated Seafood Display Case on Pedestals

IP #FSCN19236W2-AWD-CSCB-CWP-MST-P-SOH

IP #FSCN14436W-AWD-CSCB-CWP-MST-P-SOH

**100%
GUARANTEED
LEAKPROOF**

Employee Side

Customer Side

Details per sign off and specifications on pages 5-6

Approval signature: _____

Date: _____

**SCROLL DOWN FOR
ADDITIONAL VIEWS**



Atlantic Food Bars
Seafood Merchandising
Equipment Specialists

888-MEAL-SOLUTIONS
(888-632-5765)
www.atlanticfoodbars.com

28' Refrigerated Seafood Display Case on Pedestals

IP #FSCN19236W2-AWD-CSCB-CWP-MST-P-SOH

IP #FSCN14436W-AWD-CSCB-CWP-MST-P-SOH

Plan View

**100%
GUARANTEED
LEAKPROOF**

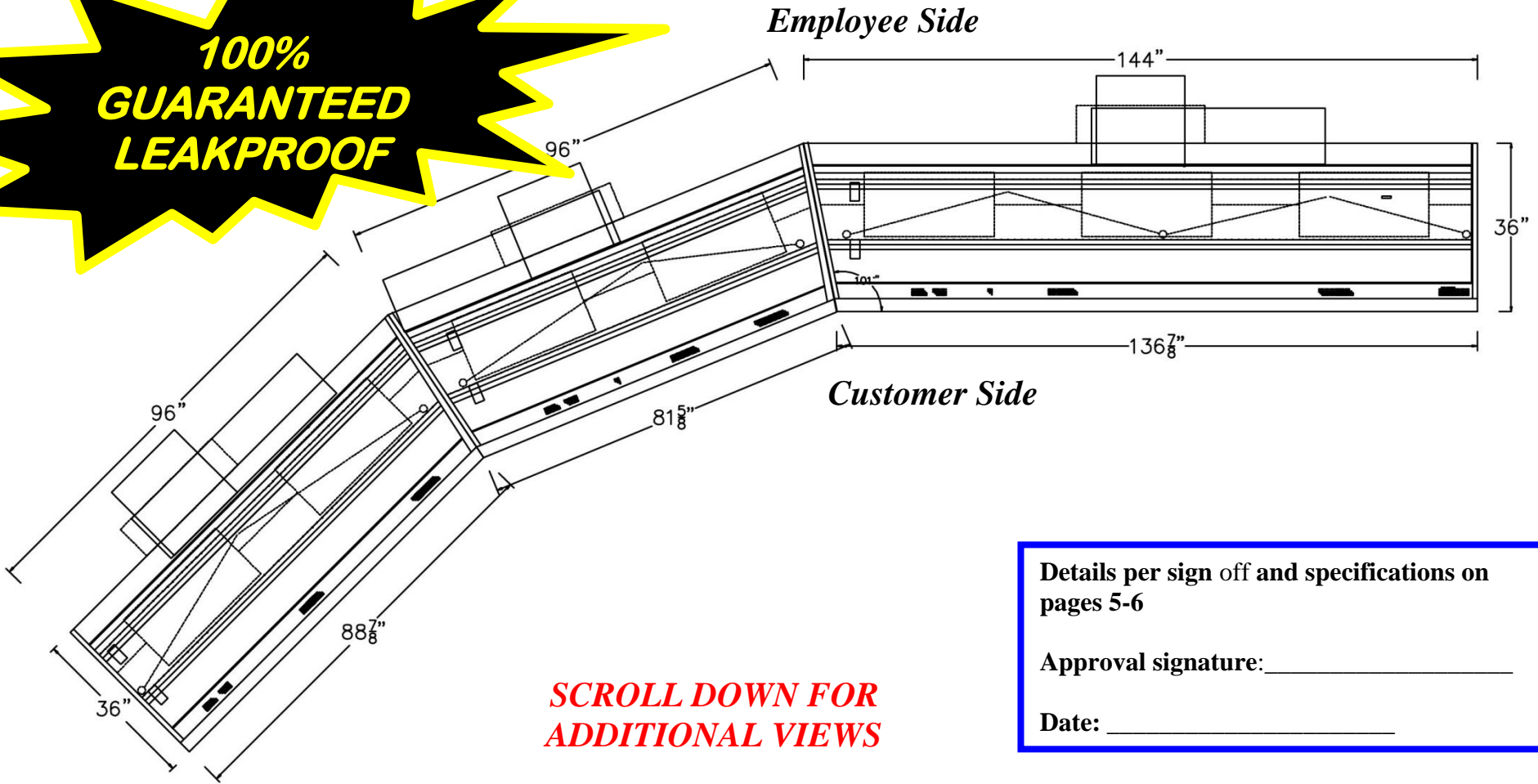

Details per sign off and specifications on pages 5-6

Approval signature: _____

Date: _____



SEA
Atlantic Food Bars
Seafood Merchandising
Equipment Specialists

888-MEAL-SOLUTIONS
(888-632-5765)
www.atlanticfoodbars.com

28' Refrigerated Seafood Display Case on Pedestals

IP #FSCN19236W2-AWD-CSCB-CWP-MST-P-SOH

IP #FSCN14436W-AWD-CSCB-CWP-MST-P-SOH

**100%
GUARANTEED
LEAKPROOF**

Pedestal plan view

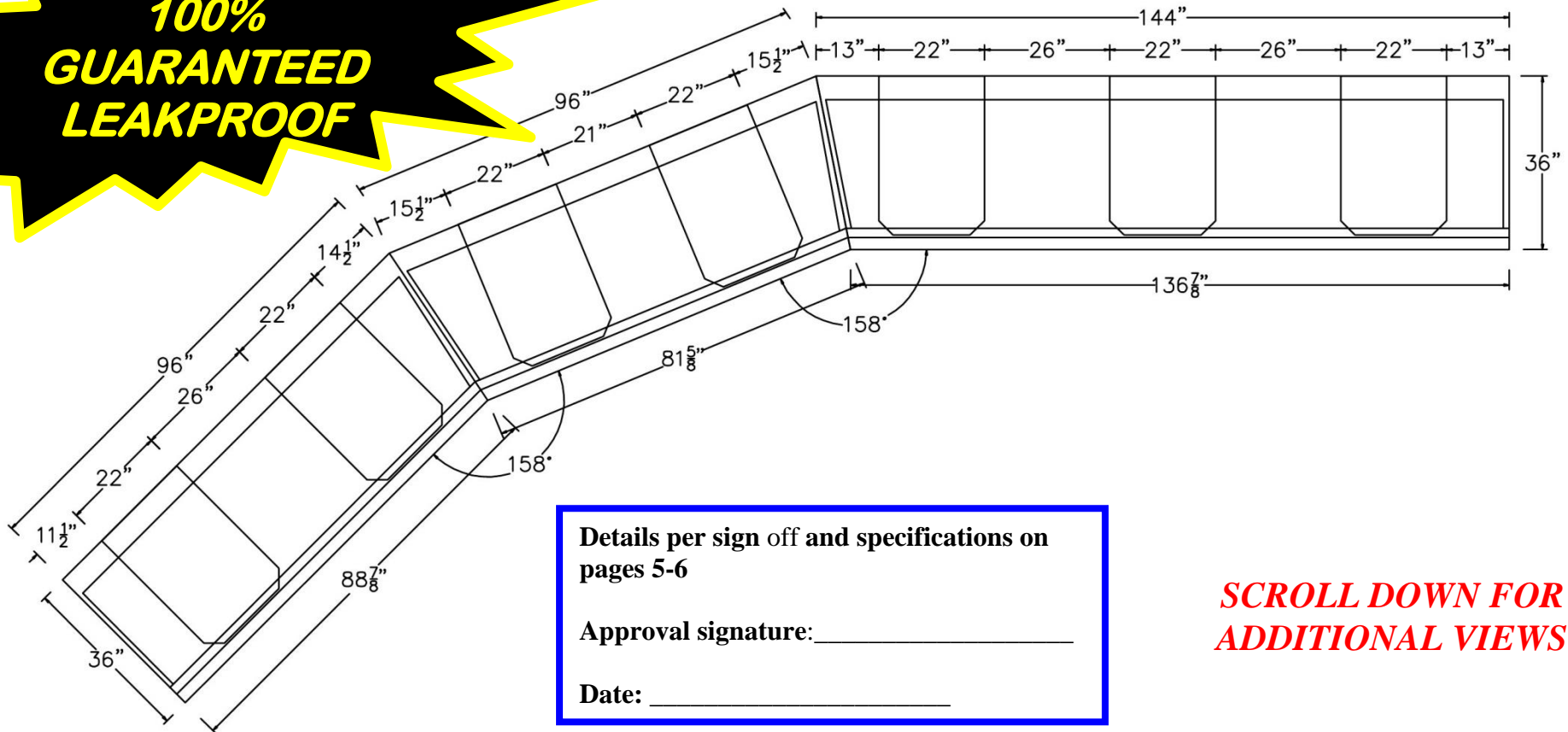

**SCROLL DOWN FOR
ADDITIONAL VIEWS**



SEA
Atlantic Food Bars
Seafood Merchandising
Equipment Specialists

888-MEAL-SOLUTIONS
(888-632-5765)
www.atlanticfoodbars.com

28' Refrigerated Seafood Display Case on Pedestals

IP #FSCN19236W2-AWD-CSCB-CWP-MST-P-SOH

IP #FSCN14436W-AWD-CSCB-CWP-MST-P-SOH

**100%
GUARANTEED
LEAKPROOF**

*Plan view showing
layout of independent
units that comprise the
28' lineup*

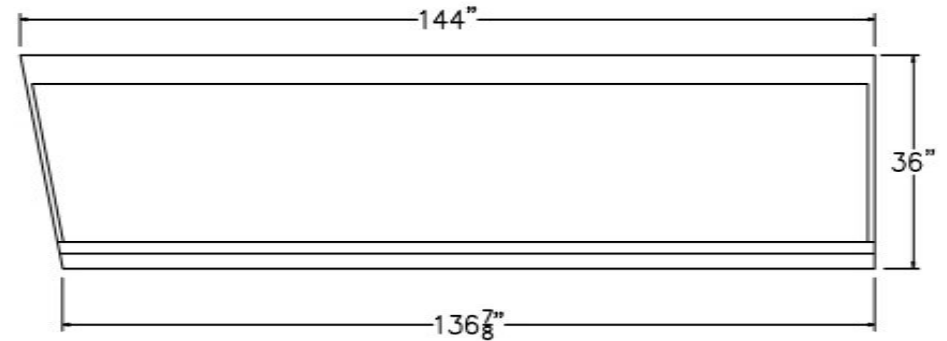
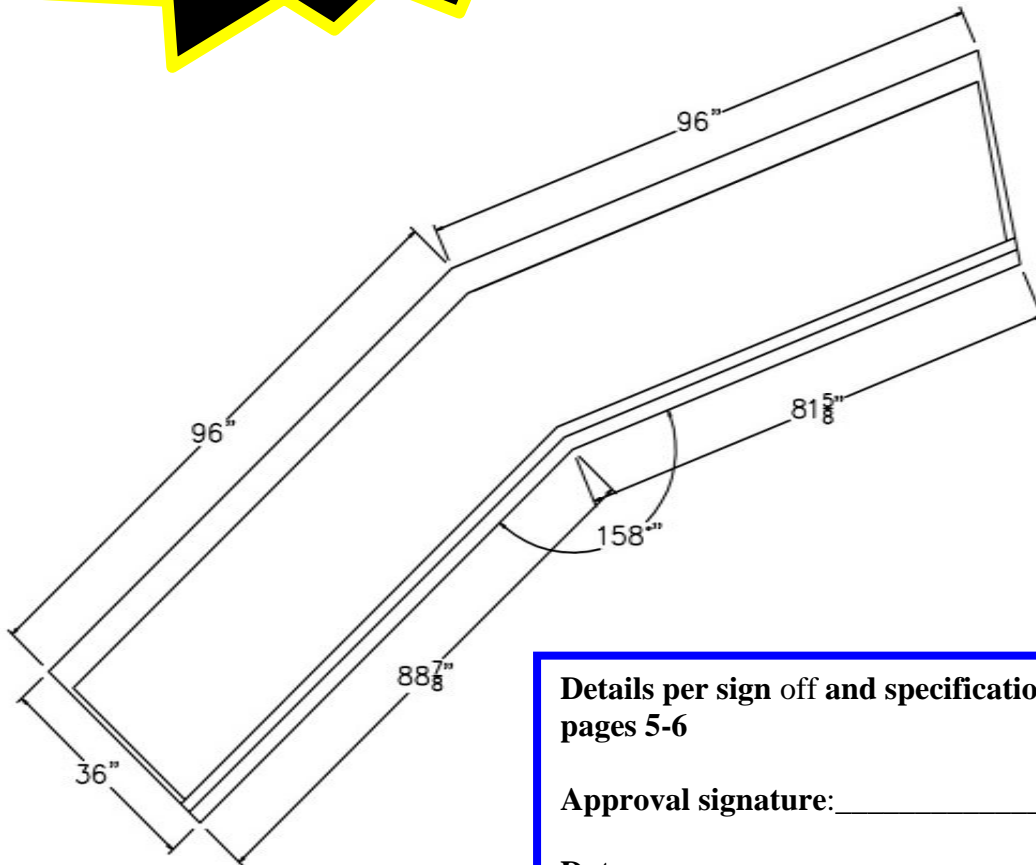

Details per sign off and specifications on pages 5-6

Approval signature: _____

Date: _____



SEA

Atlantic Food Bars
Seafood Merchandising
Equipment Specialists

888-MEAL-SOLUTIONS (888-632-5765)

www.atlanticfoodbars.com

28' Refrigerated Seafood Display Case on Pedestals

IP #FSCN19236W2-AWD-CSCB-CWP-MST-P-SOH

IP #FSCN14436W-AWD-CSCB-CWP-MST-P-SOH

Cross Sections at Scale Stand and at Customer Service Areas

Details per sign off and specifications on pages 5-6

Approval signature: _____

Date: _____

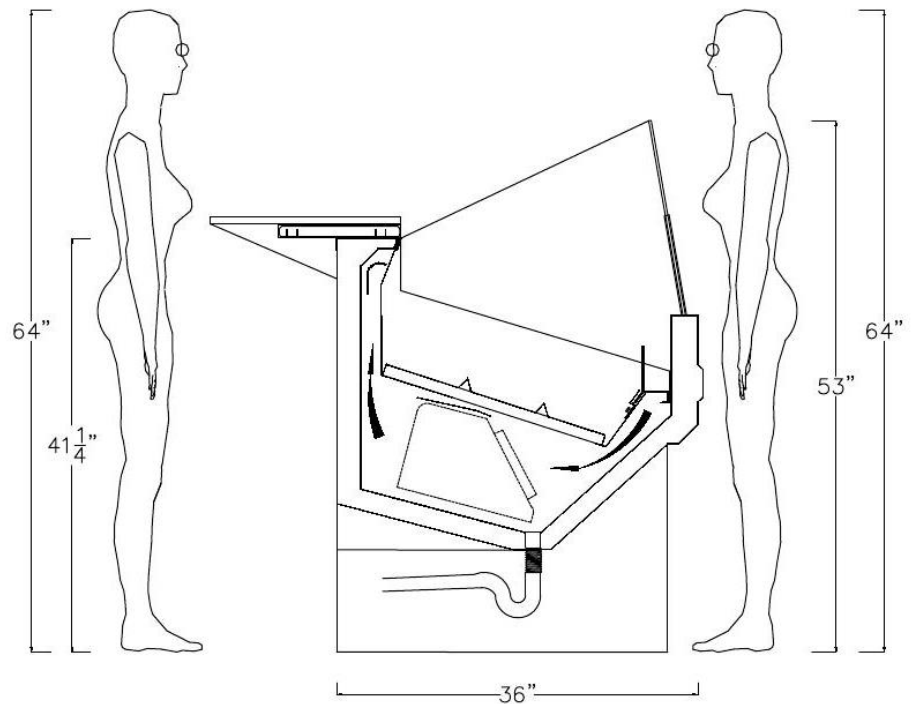
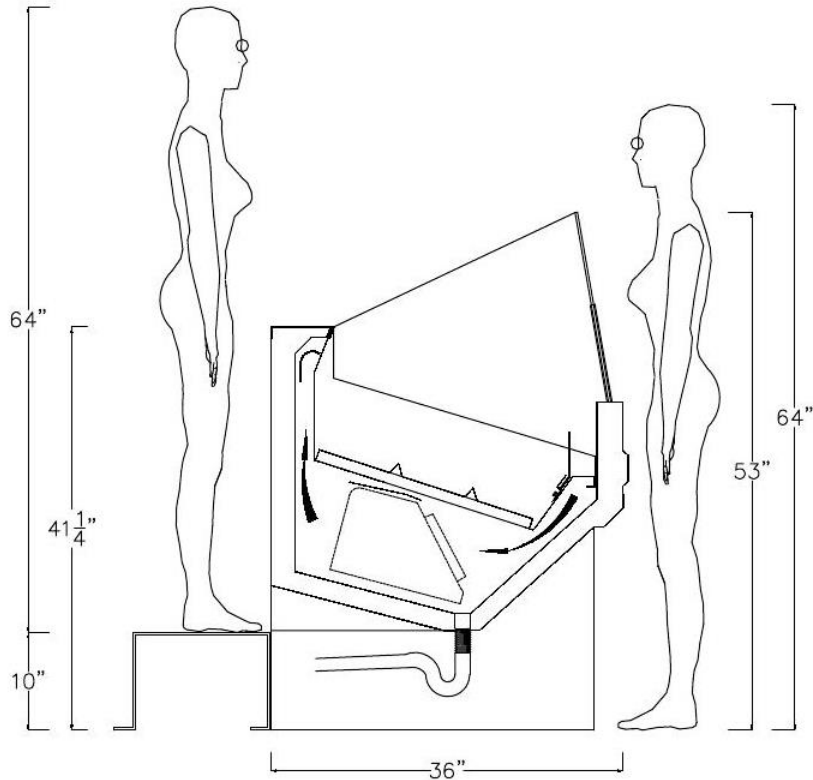

Internal Part #	Custom Description	Dimensions	Voltage	Amps 1 Ph	Electrical	BTU
FSCN19236W2-AWD-CSCB-CWP-MST-P-SOH	16' Fresh Seafood Merchandiser	16'-0" L x 36" D x 41 1/4" H	120	8.0	2 each 120V 20 Amp duplex receptacle for scales; 1 each 120V 15 Amp circuits for fans	12,000
FSCN14436W-AWD-CSCB-CWP-MST-P-SOH	12' Fresh Seafood Merchandiser	12'-7" L x 36" D x 41 1/4" H	120	6.0	1 each 120V 20 Amp duplex receptacle for scale; 1 each 120V 15 Amp circuits for fans	9,000

Total BTU load for lineup = 21,000 Will need 3 ea. 20 Amp circuits for scales, 2 ea. 15 amp circuits for coils. Suction temp = 20°



888-MEAL-SOLUTIONS (888-632-5765)

www.atlanticfoodbars.com

28' Refrigerated Seafood Display Case on Pedestals

IP #FSCN19236W2-AWD-CSCB-CWP-MST-P-SOH

IP #FSCN14436W-AWD-CSCB-CWP-MST-P-SOH

Approval – Complete All Sections

Colors:

Body: Stainless Steel

Bumper: Black

Refrigeration :

Self-Contained Remote

Refrigerant

Electric :

Voltage 120V

Phase : Single

Source : Floor Ceiling

Delivery

Site: Loading Dock Ground Level

Delivery hours :

Depth of case is 36" which will fit through narrowest space between delivery point and install location Yes No If no – CALL US ASAP

Approval signature:

Date:

See previous page for specifications table – your signature above verifies the installation site has the required power as shown

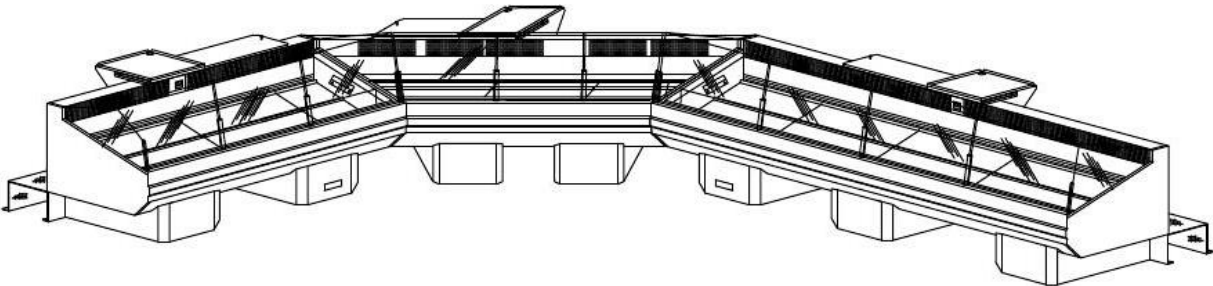

SEA
Atlantic Food Bars
Seafood Merchandising
Equipment Specialists

888-MEAL-SOLUTIONS
(888-632-5765)
www.atlanticfoodbars.com