

# Build your seafood sales and profits with our FSCN Series Full Service Refrigerated Fresh Seafood Merchandisers. Captivate customers !



Removable stainless steel drip trays feature ice stops to keep ice in place. Clear-view end panels create visibility from all angles for your shoppers. Duplex receptacles are included for scales with stainless steel scale shelves

Super cold air overflow refrigeration system keeps seafood fresh and minimizes labor. Tilt-out or swing-out tempered glass allows for easy access and cleaning from the front of the case, while anti-slip steps in the rear feature a retention channel and tip-free design to ensure safety when merchandising and selling.



Customize with countless options and accessories to make your seafood display stand out and become a full-service profit center!

This seafood merchandiser is a **MONEY MAKER** and a **SELL-THROUGH BEAST** !



**FSCN Series**  
**Full Service Refrigerated Fresh**  
**Seafood Merchandiser**



**SEA**  
**Atlantic Food Bars**  
**Hot & Cold Food Equipment Specialists**  
888-MEAL-SOLUTIONS (888-632-5765)  
info@atlanticfoodbars.com    www.atlanticfoodbars.com



# FSCN Series

## Full Service Refrigerated Fresh Seafood Merchandiser

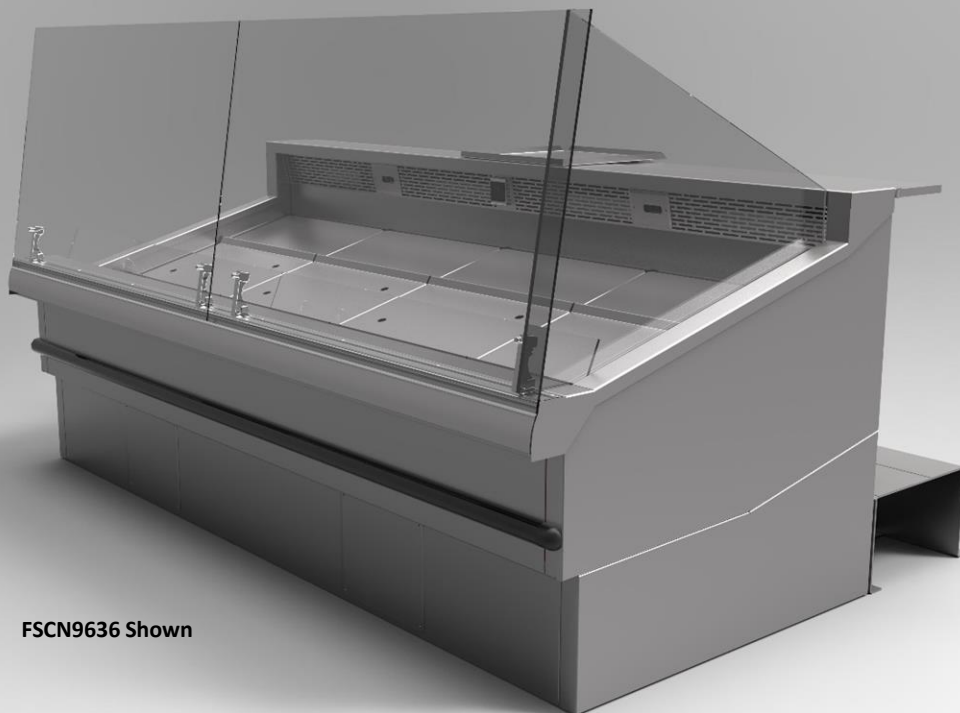

FSCN9636 Shown

### Standard Features

- 100% GUARANTEED Leak-proof design is fully welded and guaranteed for 10 years!
- Super cold air overflow remote refrigeration system
- Frameless tilt-out tempered glass
- Anti-slip steps with retention channel and tip-free design
- Clear-view end panels
- Removable stainless steel drip trays
- Stainless steel ice stops keeps ice in place
- Stainless steel scale shelf
- Duplex receptacle for scale
- Wash down hose
- Digital thermometer

### Options

- Pedestal base
- Curved glass in lieu of flat
- Diamond plate finish on body
- Refrigerated front grab & go display
- Iced front grab & go display
- Misting system
- Automatic wash down system
- Swing out glass hardware
- LED accent lighting
- Combination wrap stand with paper roll holder & cutter
- Wrap stand or bag shelf
- Angles and custom shapes and dimensions



SEA

**Atlantic Food Bars**

**Hot & Cold Food Equipment Specialists**

888-MEAL-SOLUTIONS (888-632-5765)

info@atlanticfoodbars.com

www.atlanticfoodbars.com



# FSCN Series

## Full Service Refrigerated Fresh Seafood Merchandiser

**Atlantic Food Bars** FSCN Series Full Service Refrigerated Fresh Seafood Merchandiser are covered by our INDUSTRY'S LONGEST WARRANTY – 1 year parts and labor. Warranty does not cover glass breakage or heat lamps, or abuse / misuse by operator. In line with its policy to continually improve its products, Atlantic Food Bars reserves the rights to change materials and specifications without notice.

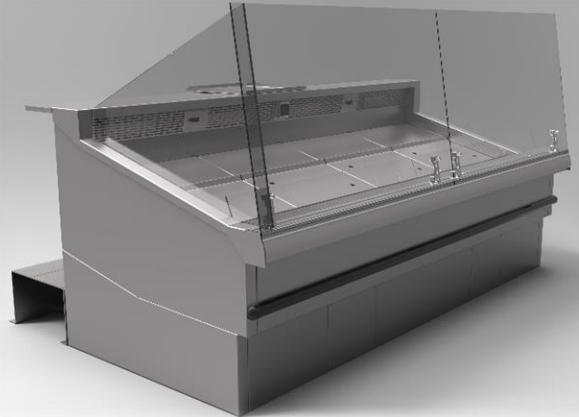
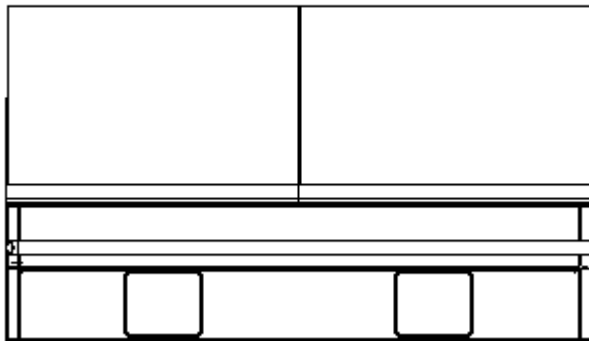
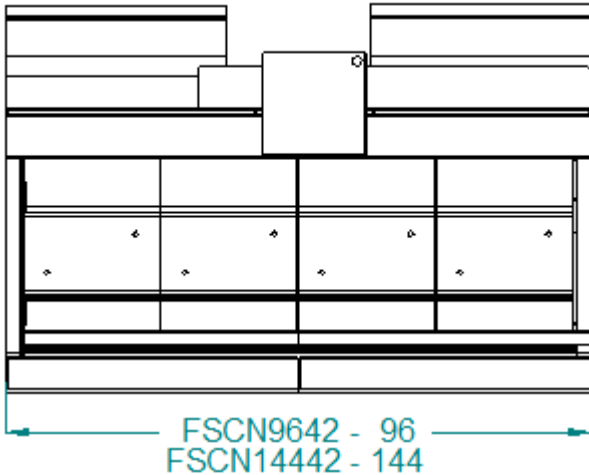

**Available in ANY length, ANY depth, ANY height, ANY shape, ANY angle.**

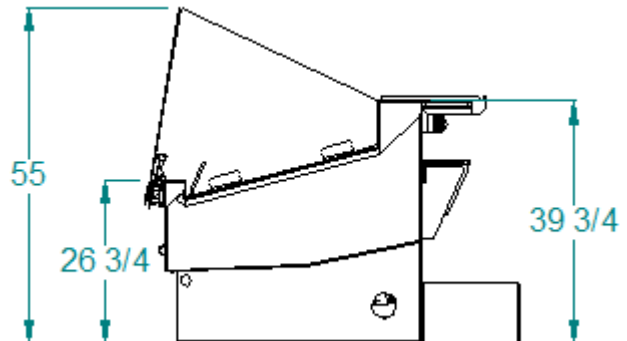

<i>IP Code</i>	<i>O.A. Dimensions L" x W" x H"</i>	<i>Electrical</i>
FSCN4842	4'-0" x 43" x 40"	1 each 120V 20 Amp duplex receptacle for scale; 1 each 120V 15 Amp circuits for fans
FSCN7242	6'-0" x 43" x 40"	
FSCN9642	8'-0" x 43" x 40"	
FSCN12042	10'-0" x 43" x 40"	
FSCN144042	12'-0" x 43" x 40"	
FSCN19242	16'-0" x 43" x 40"	



SEA

**Atlantic Food Bars**

**Hot & Cold Food Equipment Specialists**

888-MEAL-SOLUTIONS (888-632-5765)

info@atlanticfoodbars.com

www.atlanticfoodbars.com





# ***Options, accessories and features offer you the perfect merchandiser for your fresh seafood operation!***

## **INTEGRATED ENCLOSED BULK FOOD SECTION**

Offer your customers additional eye candy and generate more add-on sales by merchandising ceviche, salsas and seafood accompaniments that can be sold by the pound.

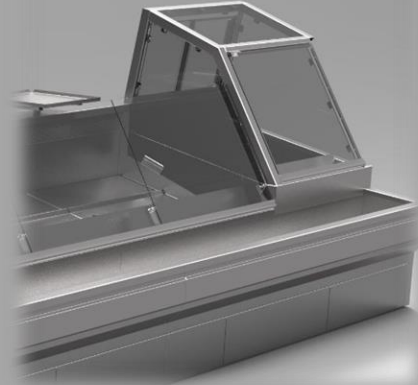

## **SELF-SERVICE FRONT CLAM BAR**

Available as refrigerated, dry or ice-only - integrated or fully mobile. Create impulse sales with grab & go packaged goods, or perishables such as bagged clams.

## **SWING-OUT GLASS HARDWARE**

As visually appealing as it is functionally appealing - less opportunity for glass breakage, and greater ease of cleanability from the front of the case.



## **LED ACCENT LIGHTING**

Make your seafood case stand out from the crowd! Brilliant illumination in color of your choice attracts shoppers like bees to honey.



## **... AND SO MUCH MORE!**

Custom angles - Diamond-plated finish - Misting system - Pedestal base - Auto-washdown system - Paper roll cutter - Curved glass - Rear poly work shelf - Wrap stand / bag shelf - Custom stainless steel food pans



**FSCN Series Options & Accessories**



**SEA**  
**Atlantic Food Bars**  
**Hot & Cold Food Equipment Specialists**  
888-MEAL-SOLUTIONS (888-632-5765)  
info@atlanticfoodbars.com    www.atlanticfoodbars.com

