

4 Tier Double-Sided Hot Chicken Merchandiser

IP #WRGCL5060-ASDS-CE

52" W x 62" D x 60" H

MASTER APPROVAL DRAWINGS

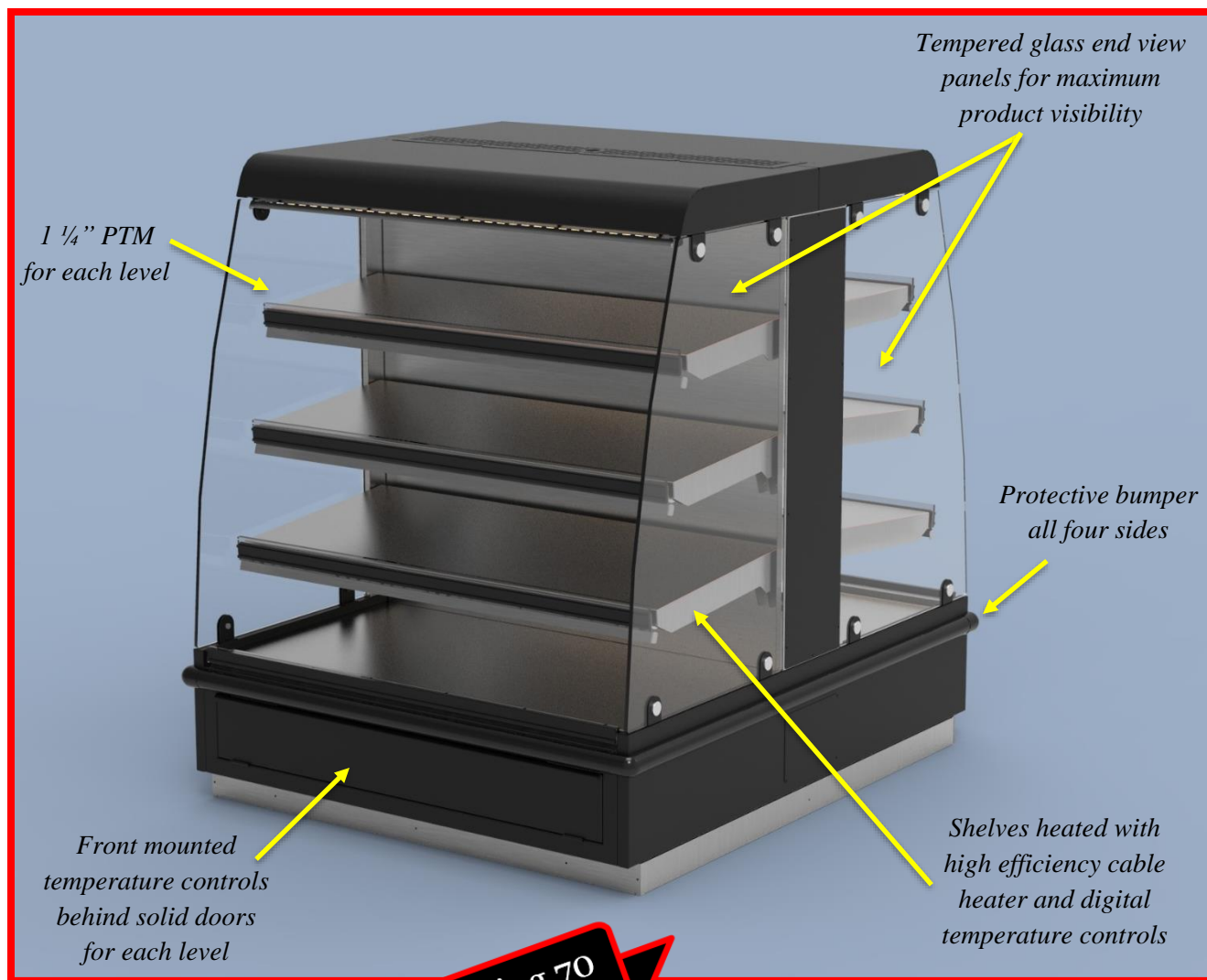

Approval – Complete All Sections

Colors:

Body: _____

Bumper: _____

Electric:

Voltage: 208V

Phase: Single ____ Three ____

Source: Ceiling ____ Floor ____

Delivery

Site: Loading Dock ____ Ground Level ____

Delivery hours: _____

Depth of case is 52" which will fit through narrowest space between delivery point and install location

Yes ____ No ____ If no – CALL US ASAP

Approval signature: _____

Date: _____

See last page for specifications table – your signature above verifies the installation site has the required power as shown

**SCROLL DOWN - PAGES 2-4 SHOW
MORE DETAILS**

Celebrating 70
Years in 2017!



HOT
Atlantic Food Bars
Hot Food Merchandising
Equipment Specialists

888-MEAL-SOLUTIONS
(888-632-5765)
www.atlanticfoodbars.com

4 Tier Double-Sided Hot Chicken Merchandiser

IP #WRGCL5060-ASDS-CE
52" W x 62" D x 60" H

Details per sign off on page 1 and specifications
on last page

Approval signature: _____

Date: _____

MASTER APPROVAL DRAWINGS

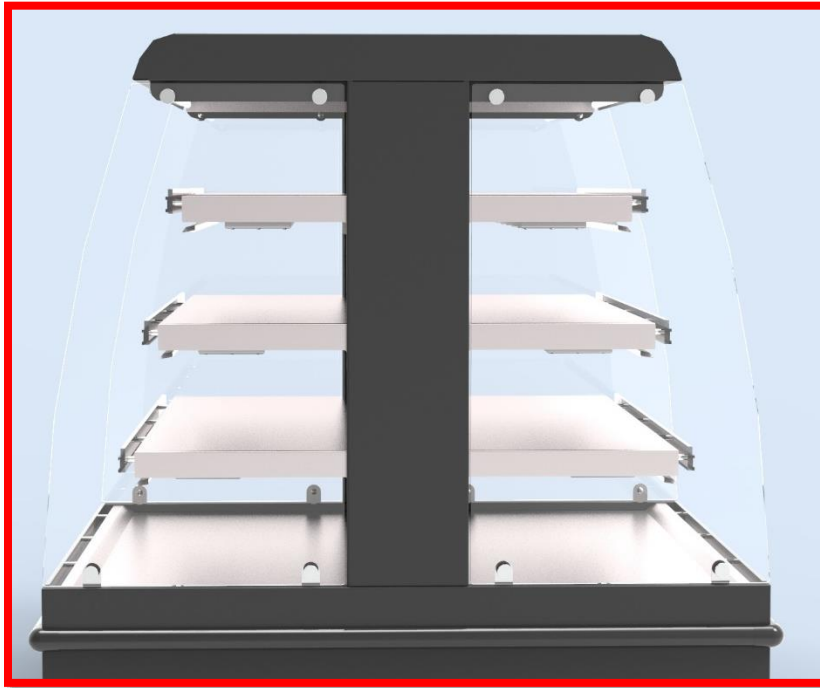

Heated stainless steel shelves individually controlled with digital temperature controls.

*Top radiant platen heaters with infinite controls over each shelf
provide consistent product temperature maintenance.*

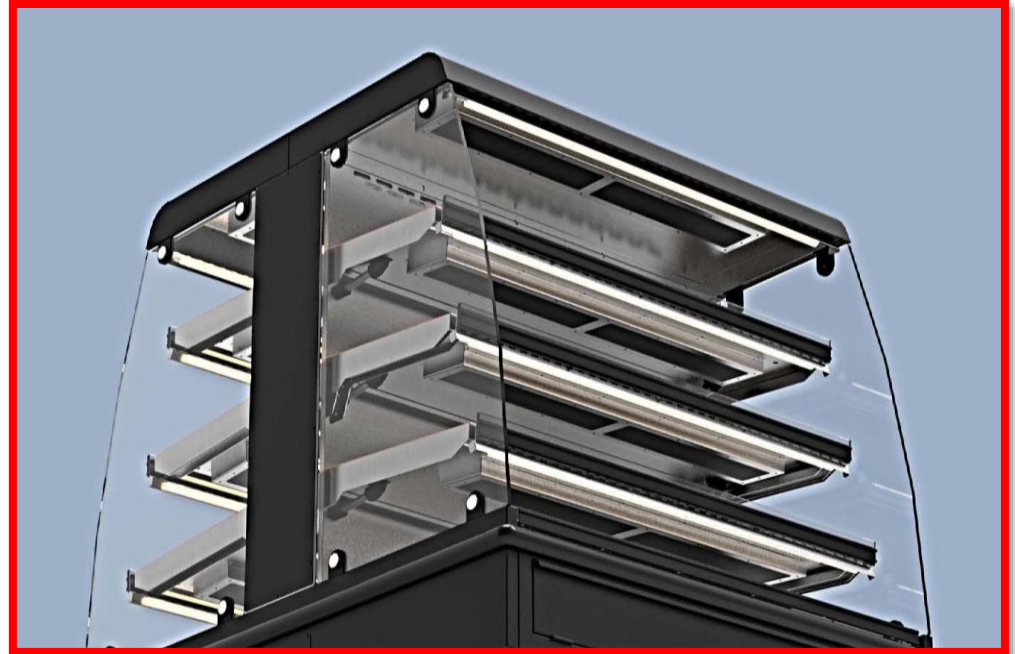

**SCROLL DOWN - PAGES 3-4 SHOW
MORE DETAILS**



*All temperature and lighting controls are in the base front for easy access.
(control panel door removed for clarity)*

**Celebrating 70
Years in 2017!**



Atlantic Food Bars
**Hot Food Merchandising
Equipment Specialists**

888-MEAL-SOLUTIONS (888-632-5765)
www.atlanticfoodbars.com

4 Tier Double-Sided Hot Chicken Merchandiser

IP #WRGCL5060-ASDS-CE
52" W x 62" D x 60" H

Shelf Dimensions and

Chicken Dome Capacity = 82

Details per sign off on page 1 and specifications on last page

Approval signature: _____

Date: _____

MASTER APPROVAL DRAWINGS

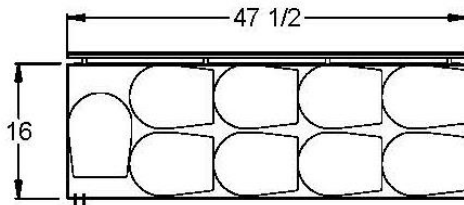

SHELF 1
(TOP)

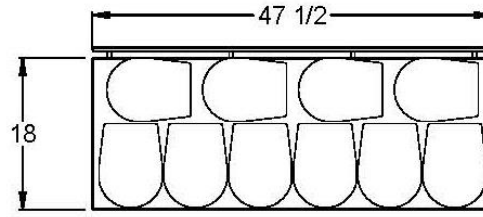

SHELF 2

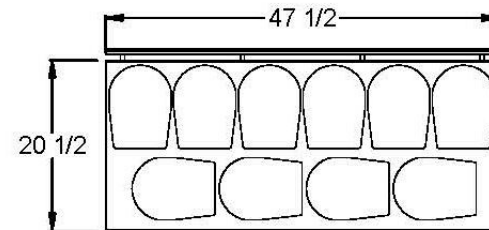
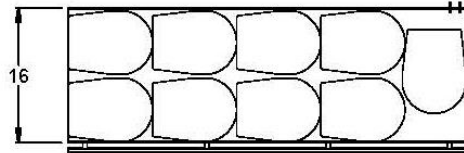

SHELF 3

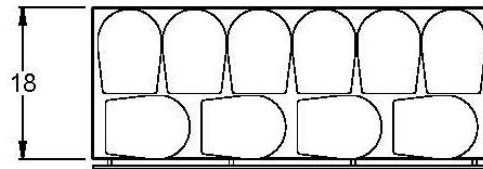

PLAN VIEW

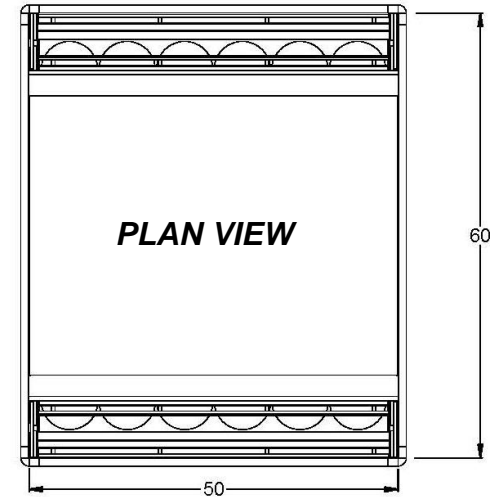

**SCROLL DOWN - PAGE 4 SHOWS
MORE DETAILS**

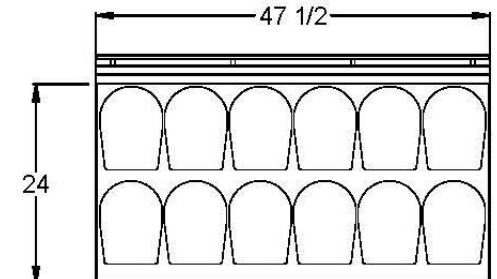

SHELF 4
(BOTTOM)

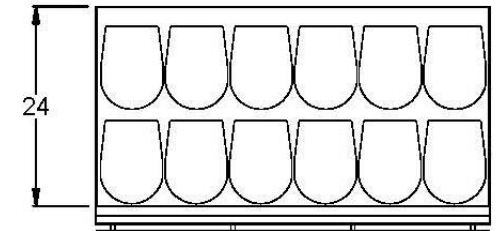

**Celebrating 70
Years in 2017!**



Atlantic Food Bars
Hot Food Merchandising
Equipment Specialists

888-MEAL-SOLUTIONS (888-632-5765)
www.atlanticfoodbars.com

4 Tier Double-Sided Hot Chicken Merchandiser

IP #WRGCL5060-ASDS-CE
52" W x 62" D x 60" H

Details per sign off on page 1 and specifications on last page

Approval signature: _____

Date: _____

MASTER APPROVAL DRAWINGS

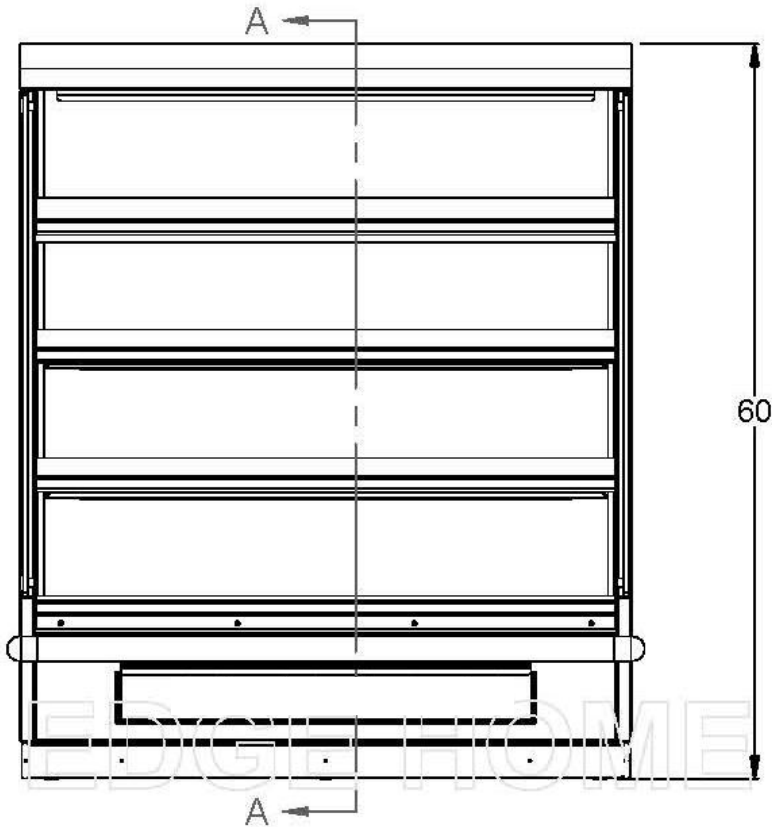

FRONT ELEVATION

Warm 27K LED lighting on each level

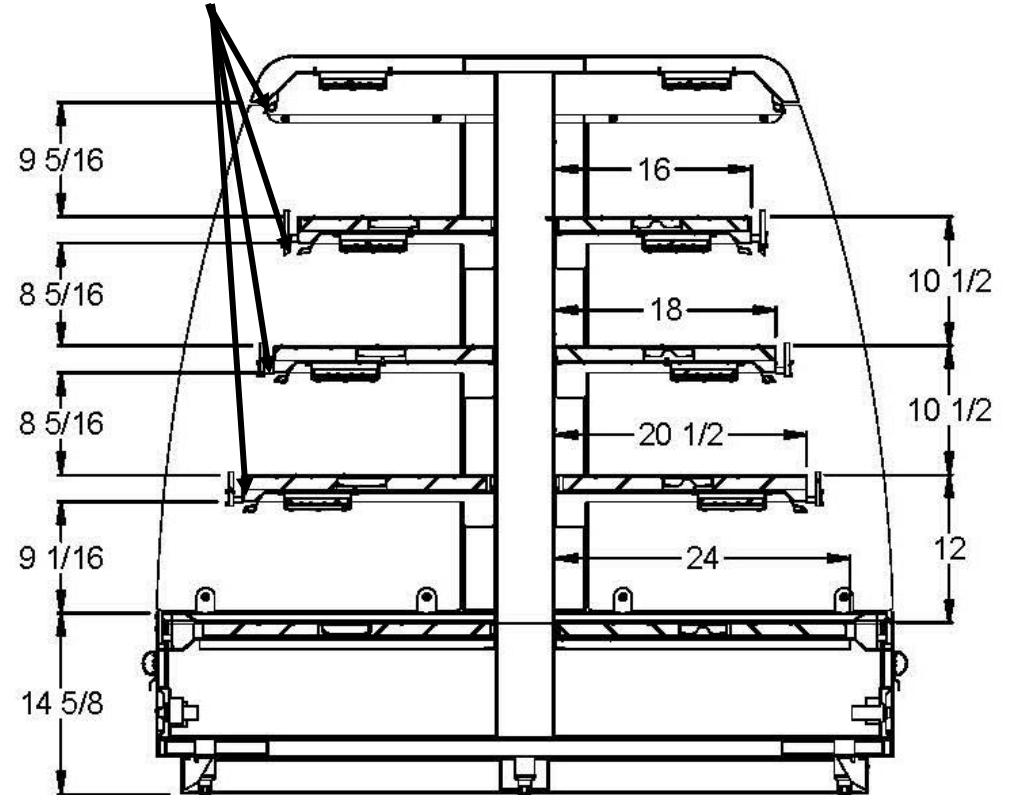

SECTION A-A

Celebrating 70 Years in 2017!

HOT

Atlantic Food Bars
Hot Food Merchandising
Equipment Specialists

888-MEAL-SOLUTIONS (888-632-5765)
www.atlanticfoodbars.com

IP CODE	DIMENSIONS L" X W" X H"	CAPACITY	ELECTRICAL		
		LEVELS	VOLTAGE	AMPS	MCA
WRGCL5060-ASDS-CE-PCB	52 x 62 x 60	4	208	23..4 - 3Ø	28.8