

**Countertop**  
**Full-Service**  
**Hot Food**  
**Merchandiser**

**SHFBBK Series**

**REPLACEMENT**  
**CASES**  
**for Discontinued**  
**BKI WDC**



*Available as*  
*Freestanding Model with Base*

***Exclusive Features :***

- \* not available on Henny Penny or Alto Shaam
- \* *Industry's LONGEST WARRANTY*  
**2 YEARS PARTS & LABOR**
- \* *Individual infinite controls on top heat*  
– each well is independent
- \* *Individual infinite controls on lower pan heat*  
– each well has its own control
- \* *The industry's EASIEST TO SERVICE*  
*design – saves you money*
- \* *Available with full base – allows you to*  
*convert from countertop to free-standing in*  
*minutes*
- \* *Optional humidity feature*
- \* *True mirror rear sliding doors show off your*  
*food and attracts shopper's attention*
- \* *Available in 3, 4, 5, 6, 7, 8, 9, 10, 12, 13 & 14*  
*well models*
- \* *Available in lengths from 48" to 192"*
- \* *Mix & Match to Create Your Perfect*  
*Functionality with Flexible*  
**REFRIGERATED / HOT / DRY**  
*Self-Service Grab & Go*  
*Merchandising and Storage Base*  
*Configurations!*
- *Displays FULL PLUS THIRD size pans in*  
*each section*
- *Brilliant interior lighting*
- *Clear end panels*



**HOT**  
**Atlantic Food Bars**  
**Hot Food Merchandising**  
**Equipment Specialists**

888-MEAL-SOLUTIONS  
(888-632-5765)  
[www.atlanticfoodbars.com](http://www.atlanticfoodbars.com)

**REPLACEMENT  
CASES  
for Discontinued  
BKI WDC**

**Countertop  
Full-Service Hot Food  
Merchandiser**

**SHFBBK  
Series**

- *The industry's **EASIEST TO SERVICE** design – saves you money*
- *True mirror rear sliding doors shows off your food and attracts shopper's attention*

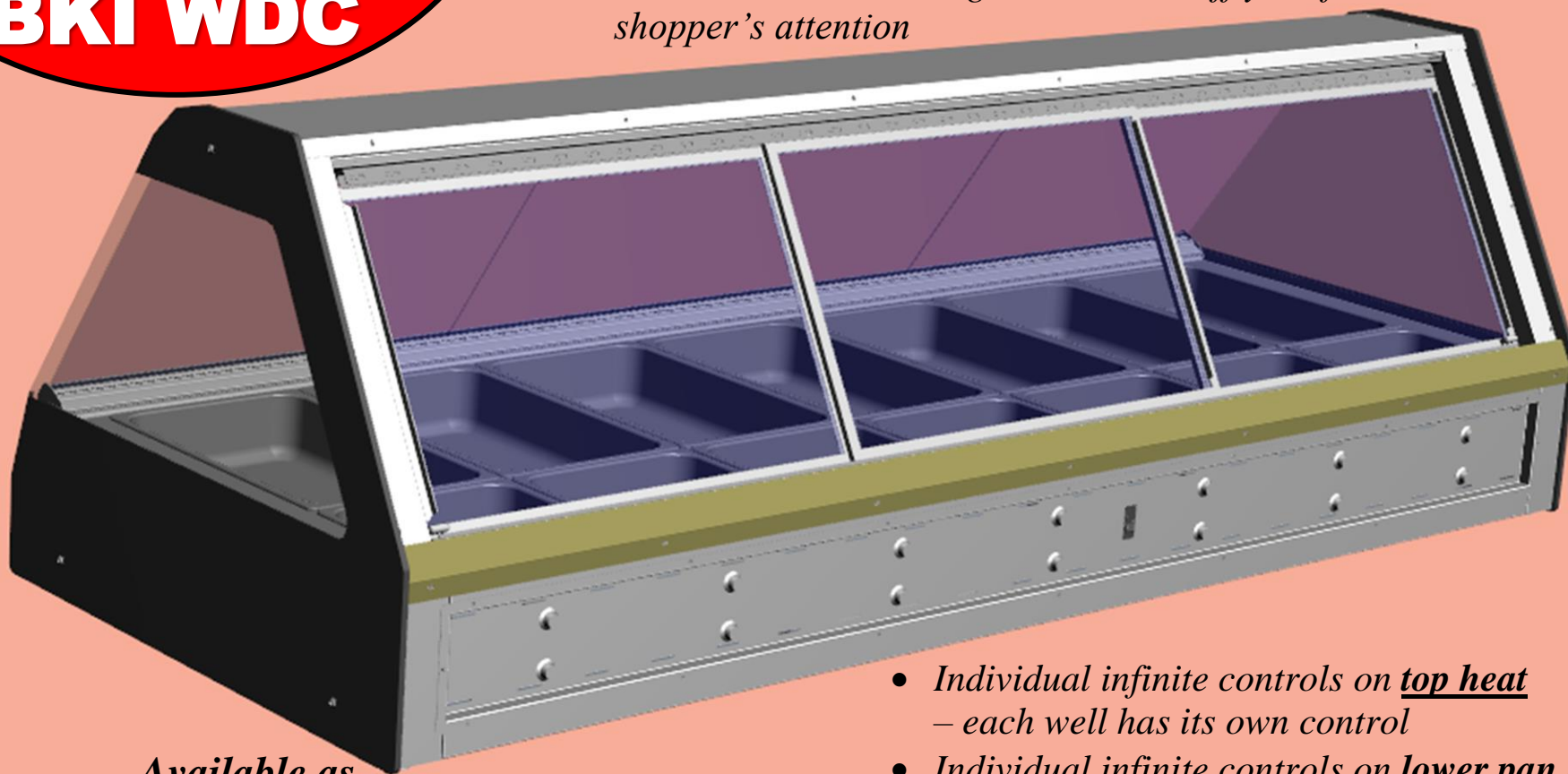

*Available as  
Freestanding Model with Base*

- *Individual infinite controls on top heat  
– each well has its own control*
- *Individual infinite controls on lower pan heat  
– each well has its own control*



**HOT**  
**Atlantic Food Bars**  
**Hot Food Merchandising**  
**Equipment Specialists**

888-MEAL-SOLUTIONS  
(888-632-5765)  
[www.atlanticfoodbars.com](http://www.atlanticfoodbars.com)

# ***8' Countertop Full-Service Hot Food Merchandiser***

**Replacement for Discontinued BKI WDC Series**

IP #SHFB9638-BK

96" L x 40" D x 32" H

**SHFB-BK  
Series**

***Countertop  
Model***

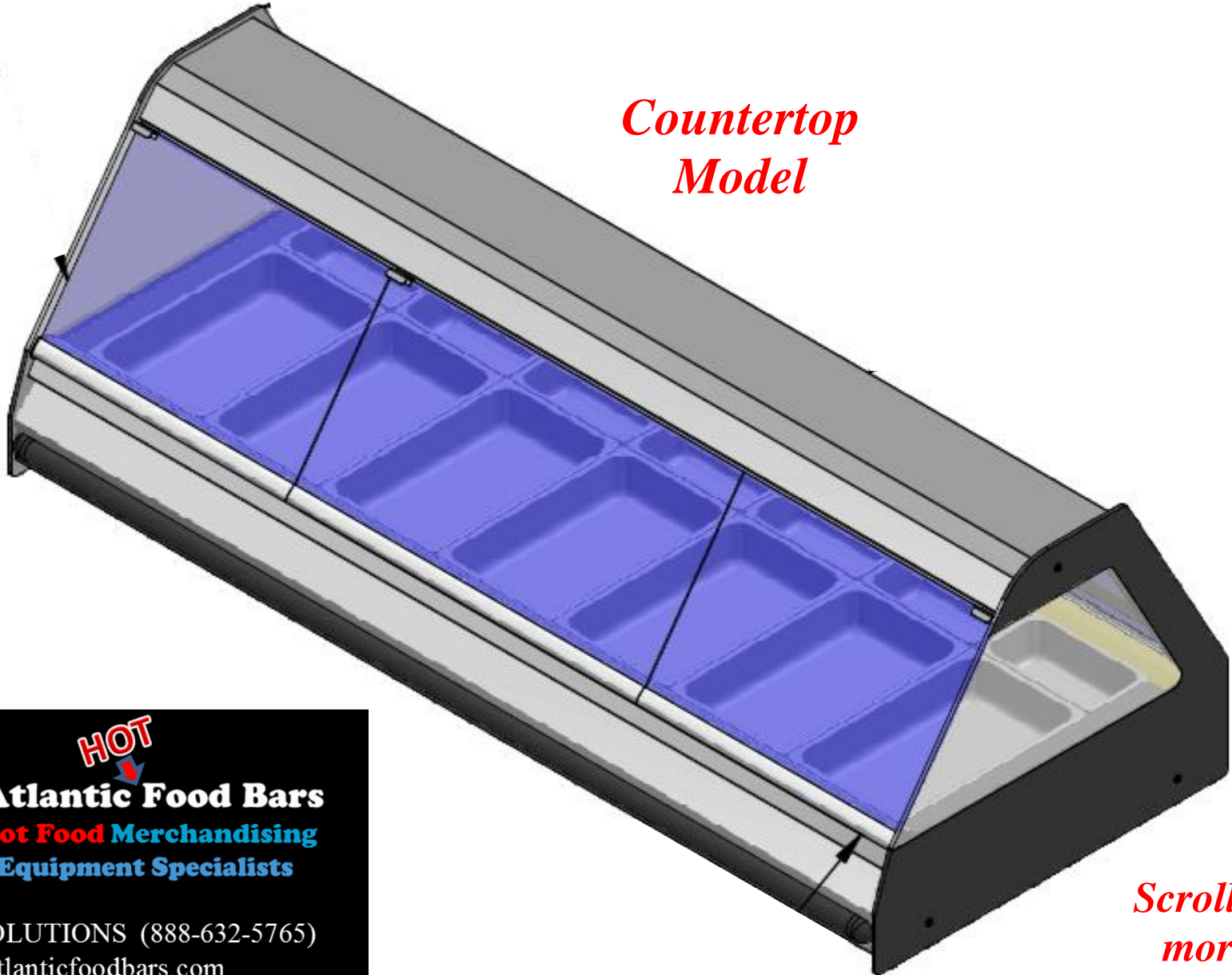

***Scroll down for  
more details***



**HOT**  
**Atlantic Food Bars**  
**Hot Food Merchandising**  
**Equipment Specialists**

888-MEAL-SOLUTIONS (888-632-5765)

[www.atlanticfoodbars.com](http://www.atlanticfoodbars.com)

# 8' Countertop Full-Service Hot Food Merchandiser

Replacement for Discontinued BKI WDC Series

IP #SHFB9638-BK

96" L x 40" D x 32" H

**SHFB-BK  
Series**

## Countertop Model

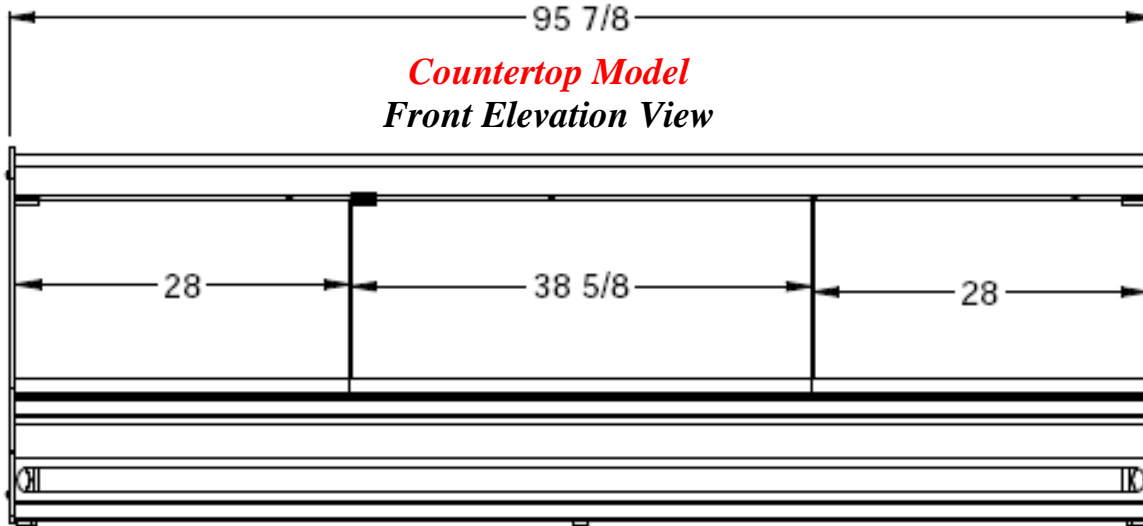

*Countertop Model  
Front Elevation View*

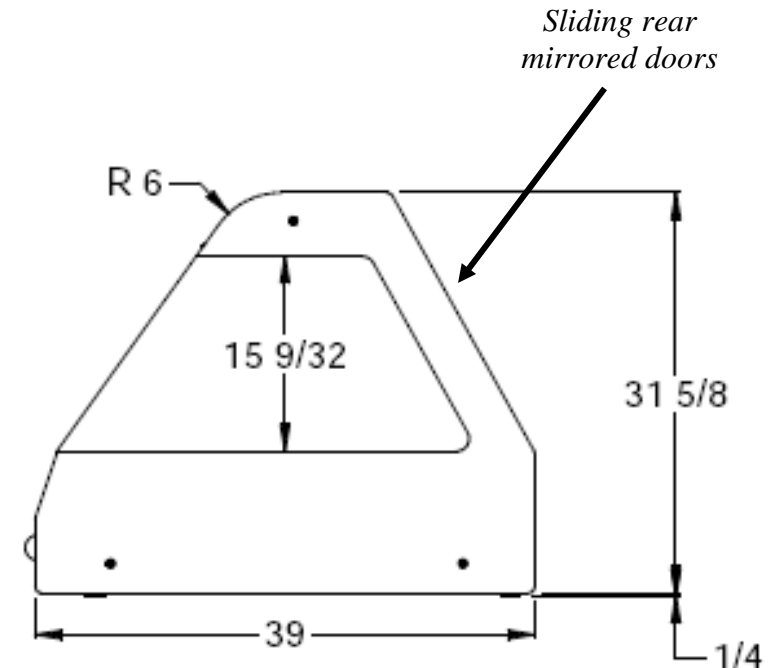

*Countertop Model  
End Section View*

*Scroll down for  
more details*



**HOT**  
**Atlantic Food Bars**  
**Hot Food Merchandising**  
**Equipment Specialists**

888-MEAL-SOLUTIONS  
(888-632-5765)  
[www.atlanticfoodbars.com](http://www.atlanticfoodbars.com)

# 8' Freestanding Full-Service Hot Food Merchandiser

**SHFB-BK Series**

**Replacement for Discontinued BKI WDC Series**

IP #SHFB9638-BK  
96" L x 40" D x 32" H

*Shown with Optional Base to make it freestanding*

*Front Row: 7 ea. full size 12" x 20" hot wells*  
*Rear Row: 7 ea. 1/3rd size 12" x 7" hot wells*

**Available with REFRIGERATED Base – Call For Info**

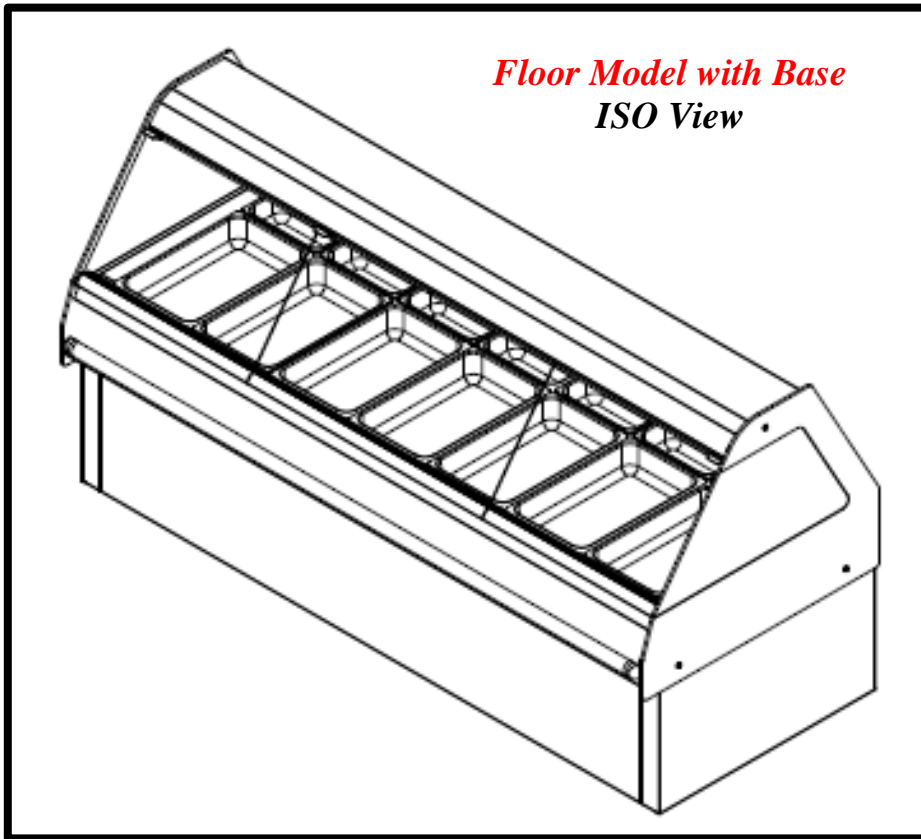

*Base can be field-retrofitted, or shipped with base installed*

*Base can be made to match any profile – any color*

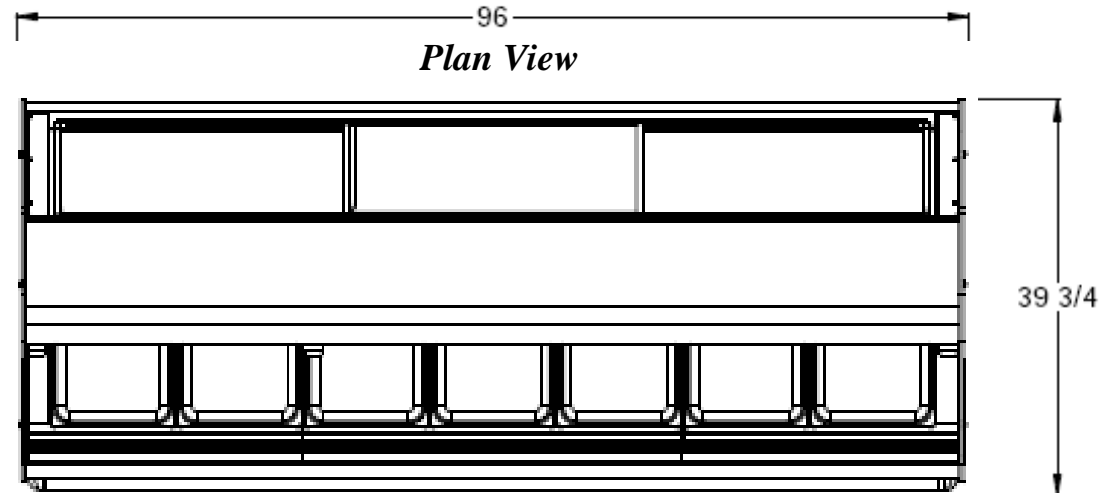
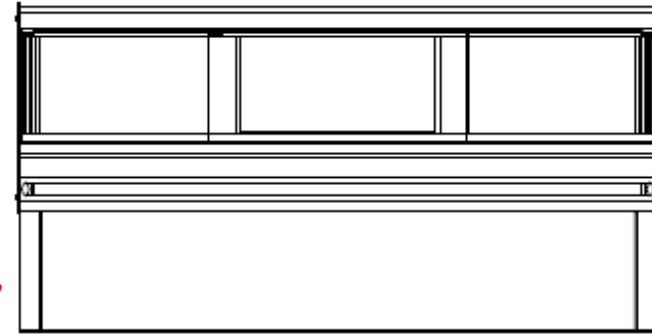

IP CODE	DIMENSIONS L" X W" X H"	CAPACITY	ELECTRICAL		
		HOT 12 X 27	VOLTAGE	AMPS	MCA
SHFB9638-BK	96 x 39.75 x 49.19	7	208	47.45 - 1Ø 31.93 - 3Ø	59.3 - 1Ø 39.9 - 3Ø

**HOT**

**Atlantic Food Bars**  
**Hot Food Merchandising**  
**Equipment Specialists**

888-MEAL-SOLUTIONS (888-632-5765)  
[www.atlanticfoodbars.com](http://www.atlanticfoodbars.com)

**Freestanding**  
**with Base**  
**Full-Service**  
**Hot Food**  
**Merchandiser**

**SHFBBK Series**

**Discontinued**  
**BKI WDC**  
**REPLACEMENT**  
**CASES**



*Available as Countertop  
Model without Base*

***Exclusive Features :***

- \* not available on Henny Penny or Alto Shaam
- \* *Industry's LONGEST WARRANTY*  
**2 YEARS PARTS & LABOR**
- \* *Available in 3, 4, 5, 6, 7, 8, 9, 10, 12, 13 & 14 well models*
- \* *Available in lengths from 48" to 192"*
- \* *Individual infinite controls on top heat*  
– each well is independent
- \* *Individual infinite controls on lower pan heat*  
– each well has its own control
- \* *The industry's EASIEST TO SERVICE design*  
– saves you money
- \* *Convenient design allows you to convert free-standing to countertop model in minutes anytime in the future*
- \* *Optional humidity feature*
- \* *True mirror rear sliding doors show off your food and attracts shopper's attention*
- \* *Base can be field-retrofitted, or shipped with base installed*
- \* *Base can match any profile – any color*
- \* *Mix & Match to Create Your Perfect Functionality with Flexible*  
**REFRIGERATED / HOT / DRY Self-Service Grab & Go Merchandising and Storage Base Configurations!**
- *Displays FULL PLUS THIRD size pans in each section*
- *Brilliant interior lighting*
- *Clear end panels*



**HOT**  
**Atlantic Food Bars**  
**Hot Food Merchandising**  
**Equipment Specialists**

888-MEAL-SOLUTIONS  
(888-632-5765)  
[www.atlanticfoodbars.com](http://www.atlanticfoodbars.com)

**Countertop Full-Service  
Hot Food Merchandiser**

**SHFBBK  
Series**

**REPLACEMENT  
CASES  
for Discontinued  
BKI WDC**

*Scroll down to learn more about the industry's  
most flexible merchandising system...*

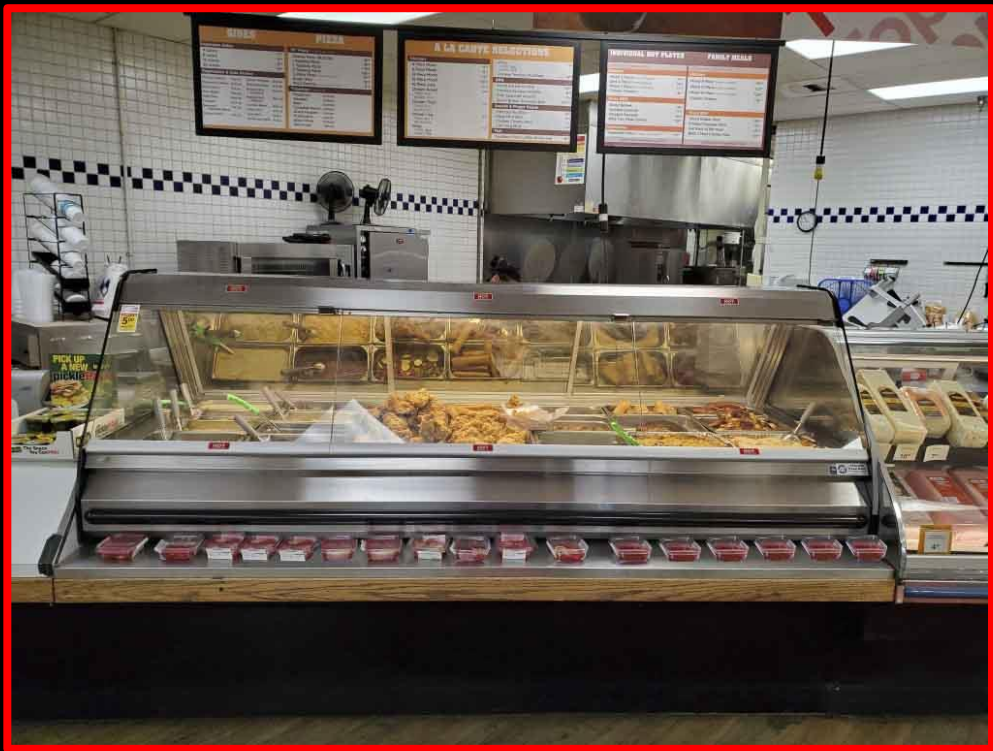

*Scroll down  
for more*

**HOT**  
**Atlantic Food Bars**  
Hot Food Merchandising  
Equipment Specialists

888-MEAL-SOLUTIONS  
(888-632-5765)  
[www.atlanticfoodbars.com](http://www.atlanticfoodbars.com)

# Countertop *Full-Service* *Hot Food Merchandiser*

**SHFBBK  
Series**



**REPLACEMENT  
CASES  
for Discontinued  
BKI WDC**



**HOT**  
**Atlantic Food Bars**  
**Hot Food Merchandising**  
**Equipment Specialists**

888-MEAL-SOLUTIONS (888-632-5765)  
[www.atlanticfoodbars.com](http://www.atlanticfoodbars.com)



**Countertop**  
**Full-Service Hot**  
**Food Merchandiser**

**REPLACEMENT**  
**CASES**  
**for Discontinued**  
**BKI WDC**

IP CODE	DIMENSIONS L" X W" X H"	CAPACITY
		HOT 12 X 27
SHFBBK4838	48 x 39 x 31	3
SHFBBK6038	60 x 39 x 31	4
SHFBBK7238	72 x 39 x 31	5
SHFBBK8438	84 x 39 x 31	6
SHFBBK9638	96 x 39 x 31	7
SHFBBK10838	108 x 39 x 31	7
SHFBBK12038	120 x 39 x 31	8
SHFBBK13238	132 x 39 x 31	9
SHFBBK14438	144 x 39 x 31	10
SHFBBK15638	156 x 39 x 31	11
SHFBBK16838	168 x 39 x 31	12
SHFBBK18038	180 x 39 x 31	13
SHFBBK19238	192 x 39 x 31	14

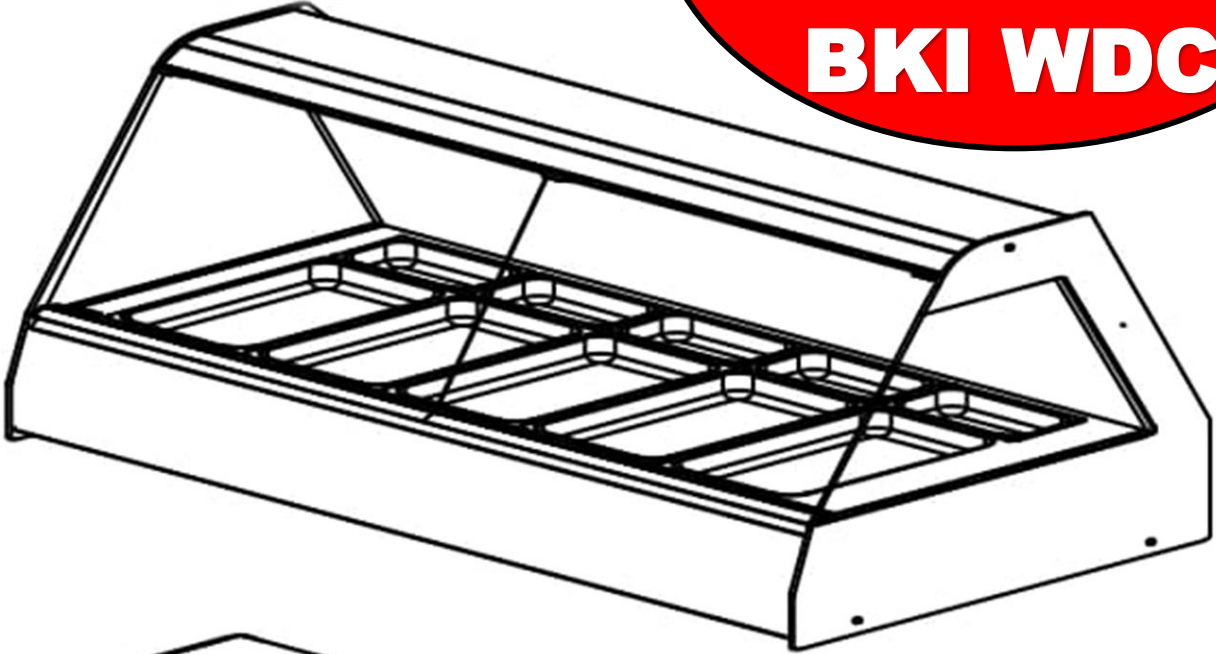

6' five pan size shown

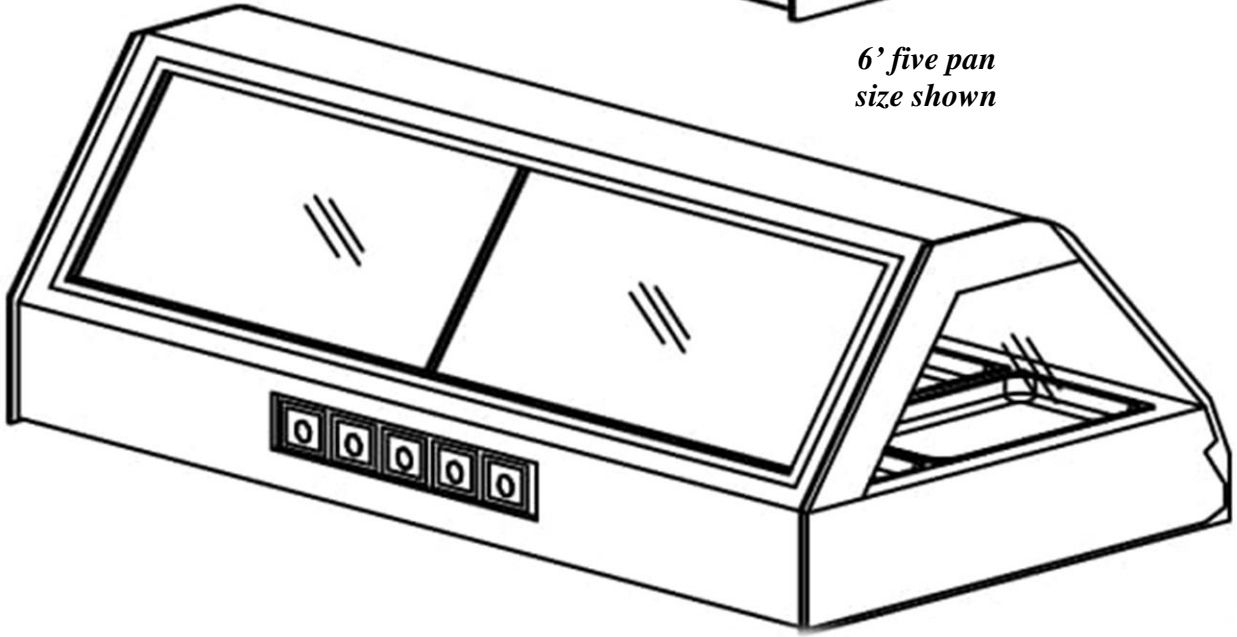

**SHFBBK Series**  
*Available in lengths from 4' to 16'*

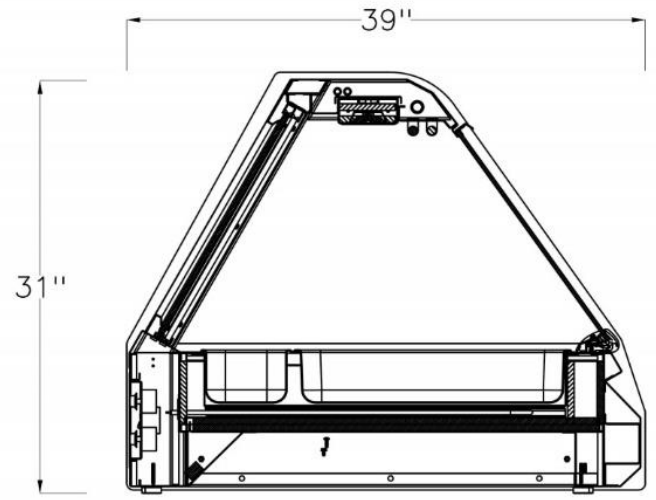

**Celebrating 70**  
**Years in 2017!**



**HOT**  
**Atlantic Food Bars**  
**Hot Food Merchandising**  
**Equipment Specialists**

888-MEAL-SOLUTIONS (888-632-5765)  
[www.atlanticfoodbars.com](http://www.atlanticfoodbars.com)

**Freestanding Model**  
**with Base**

**Full-Service Hot  
Food Merchandiser**

**REPLACEMENT  
CASES  
for Discontinued  
BKI WDC**

IP CODE	DIMENSIONS L" X W" X H"	CAPACITY
		HOT 12 X 27
SHFBBK4838	48 x 39 x 31	3
SHFBBK6038	60 x 39 x 31	4
SHFBBK7238	72 x 39 x 31	5
SHFBBK8438	84 x 39 x 31	6
SHFBBK9638	96 x 39 x 31	7
SHFBBK10838	108 x 39 x 31	7
SHFBBK12038	120 x 39 x 31	8
SHFBBK13238	132 x 39 x 31	9
SHFBBK14438	144 x 39 x 31	10
SHFBBK15638	156 x 39 x 31	11
SHFBBK16838	168 x 39 x 31	12
SHFBBK18038	180 x 39 x 31	13
SHFBBK19238	192 x 39 x 31	14



5' four pan  
size shown

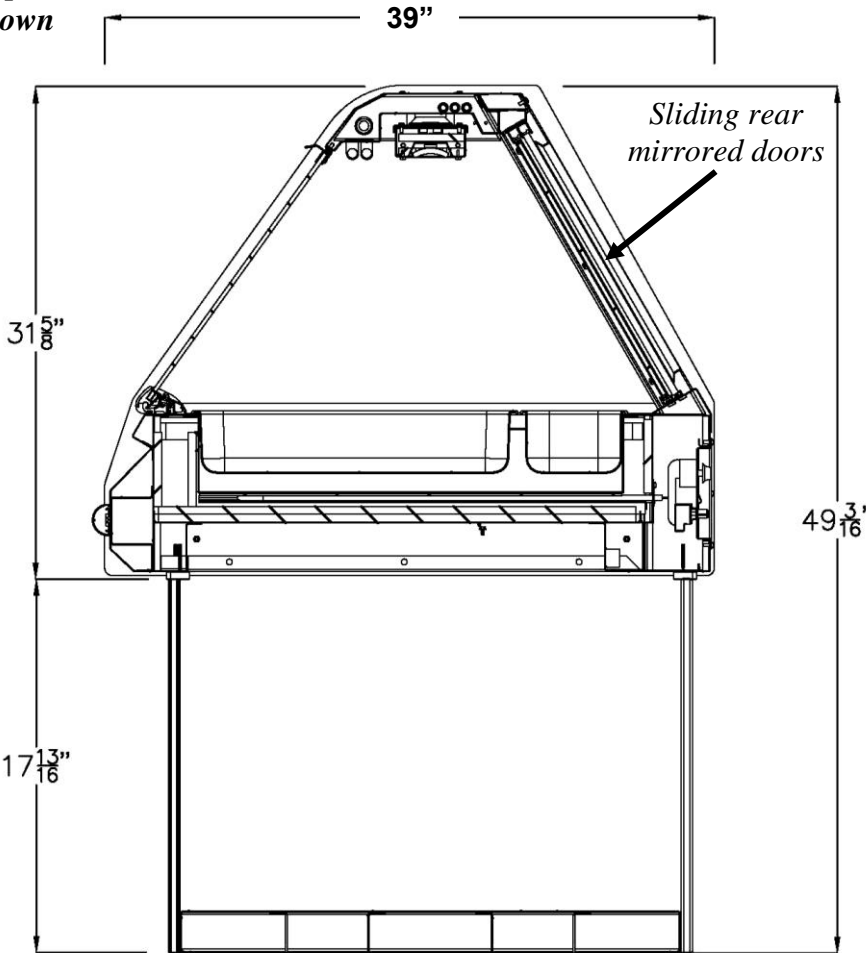

Cross Section

Celebrating 70  
Years in 2017!

**HOT**

**Atlantic Food Bars**  
Hot Food Merchandising  
Equipment Specialists

888-MEAL-SOLUTIONS (888-632-5765)  
www.atlanticfoodbars.com

**SHFBBK  
Series**  
Available in lengths  
from 4' to 16'

# Countertop

**Hot Grab & Go Self-Service**

**Hot Food Merchandiser**

**Matches Full-Service SHFBBK Series /  
Discontinued BKI WDC Series**

**SHFBBK-CEC  
Series**

IP CODE	DIMENSIONS L" X W" X H"	LEVELS	CAPACITY
			HOT Chickens
SHFBBK-CEC24	24 x 39 x 31	1	8
SHFBBK-CEC36	36 x 39 x 31	1	12
SHFBBK-CEC48	48 x 39 x 31	1	16
SHFBBK-CEC24-2	24 x 39 x 31	2	12
SHFBBK-CEC36-2	36 x 39 x 31	2	18
SHFBBK-CEC48-2	48 x 39 x 31	2	24

24" CEC One level

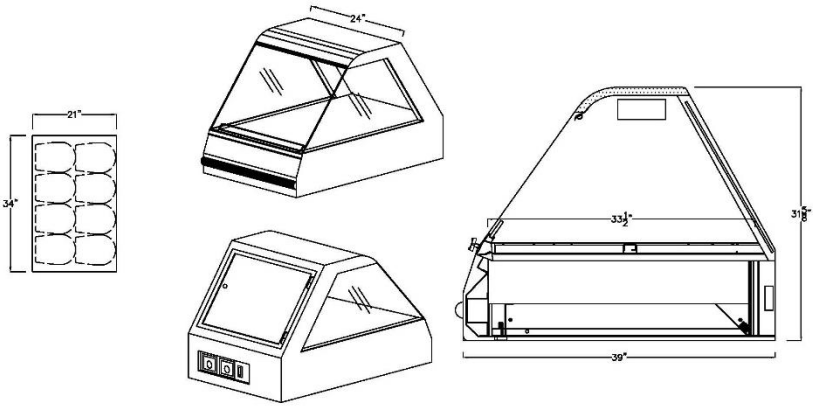

36" CEC One level

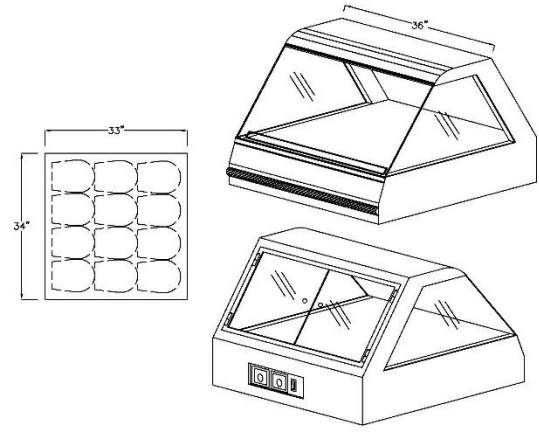

48" CEC One level

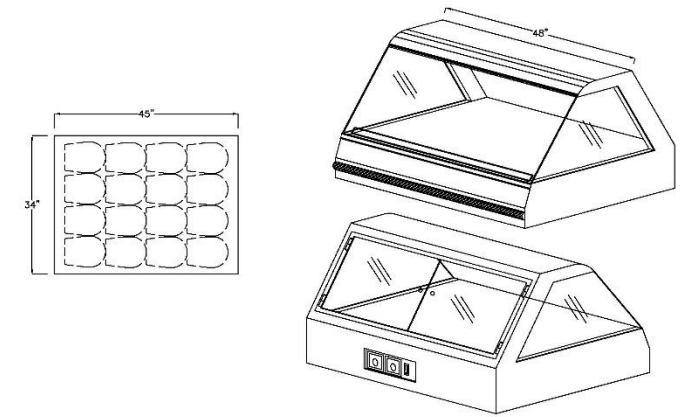

24" CEC2 Two level

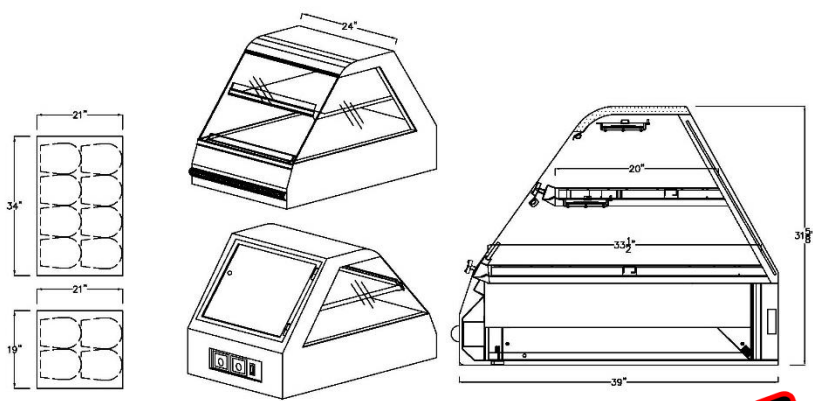

36" CEC2 Two level

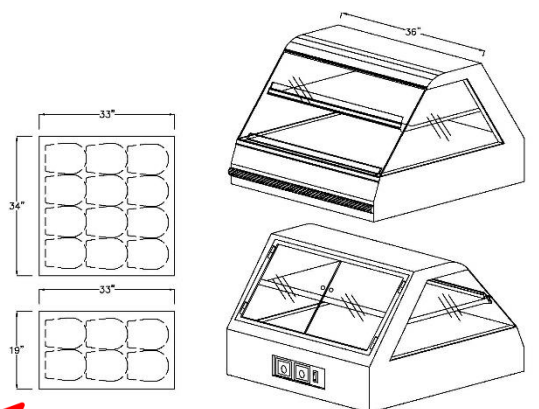

48" CEC2 Two level

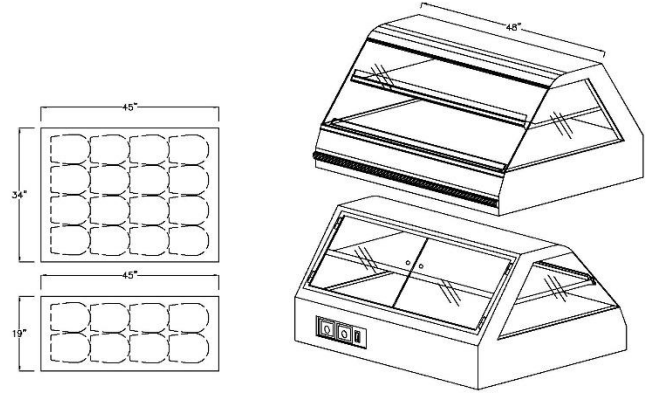

**Celebrating 70  
Years in 2017!**



**Atlantic Food Bars**  
Hot Food Merchandising  
Equipment Specialists

**HOT**

888-MEAL-SOLUTIONS  
(888-632-5765)  
[www.atlanticfoodbars.com](http://www.atlanticfoodbars.com)

***Heated / Refrigerated / Dry Base  
Merchandising & Storage Modules***

*For Full-Service SHFBBK Series /  
Discontinued BKI WDC Series*

**SHFBBK-HBM  
SHFBBK-RBM  
SHFBBK-DBM Series**

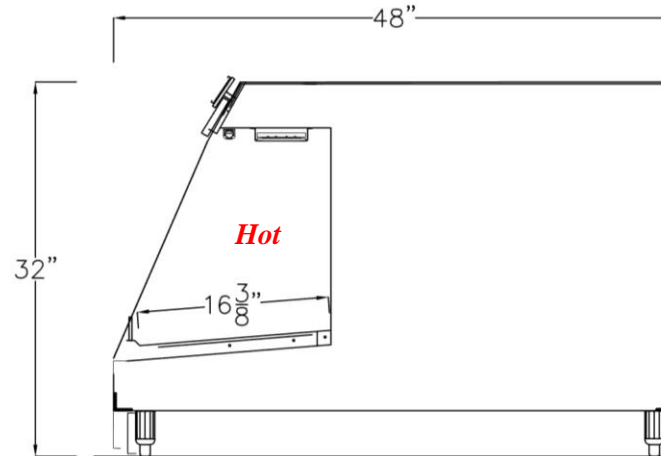
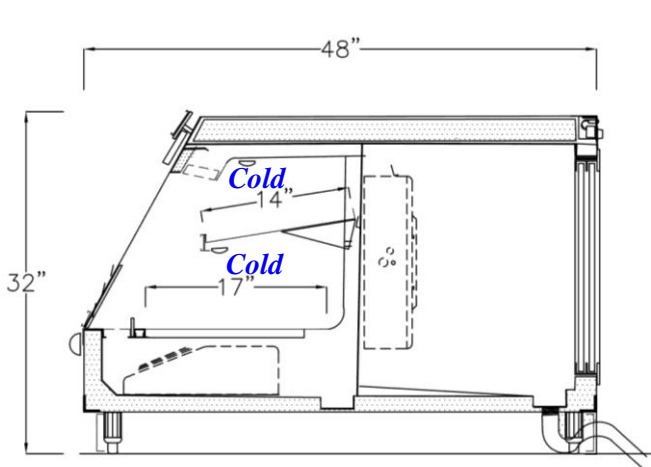
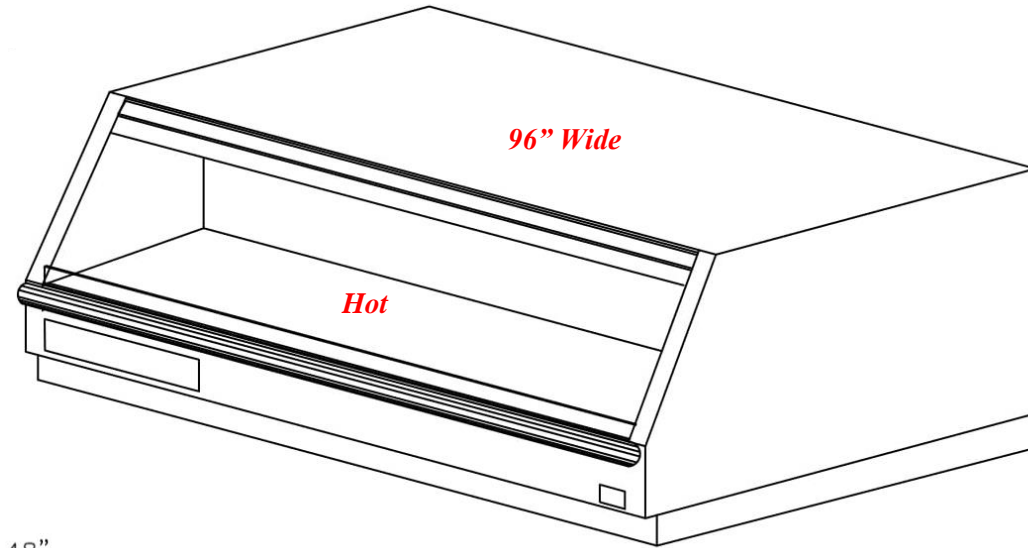
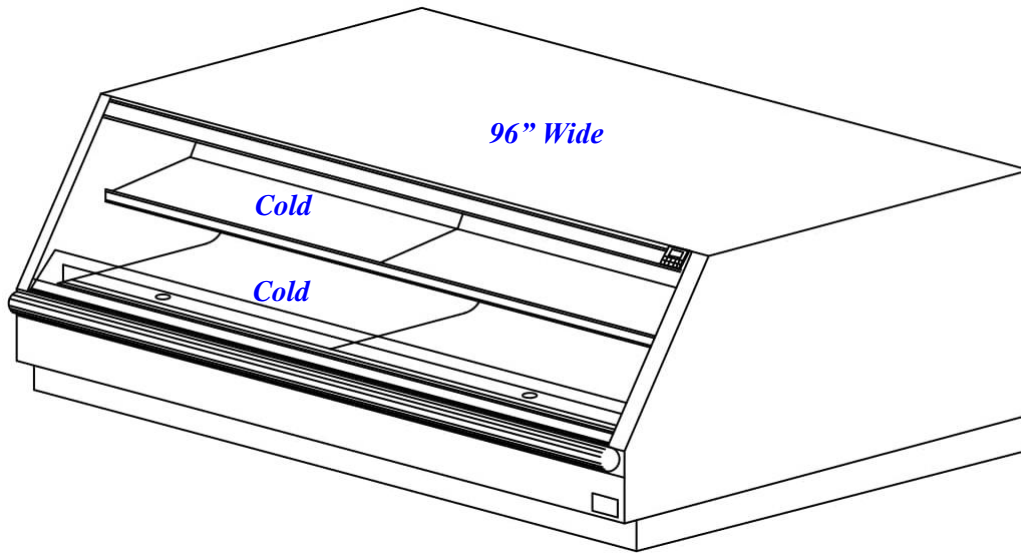

*Available with  
1 or 2 levels*

**Celebrating 70  
Years in 2017!**

*Shown with dry or refrigerated storage on employee side –  
available with remote or self-contained refrigeration systems*



**Atlantic Food Bars**  
**Hot & Cold Food**  
**Merchandising Equipment**  
**Specialists**

888-MEAL-SOLUTIONS (888-632-5765)  
[www.atlanticfoodbars.com](http://www.atlanticfoodbars.com)

# The Industry's Most Flexible Merchandising & Storage System

**1,000's of Hot / Cold / Dry Full and Self  
Service Mix & Match Configurations**

*8' case consisting of 5' four well hot service case  
and 3' two level hot grab & go on top and 8'  
refrigerated grab & go base module on bottom*

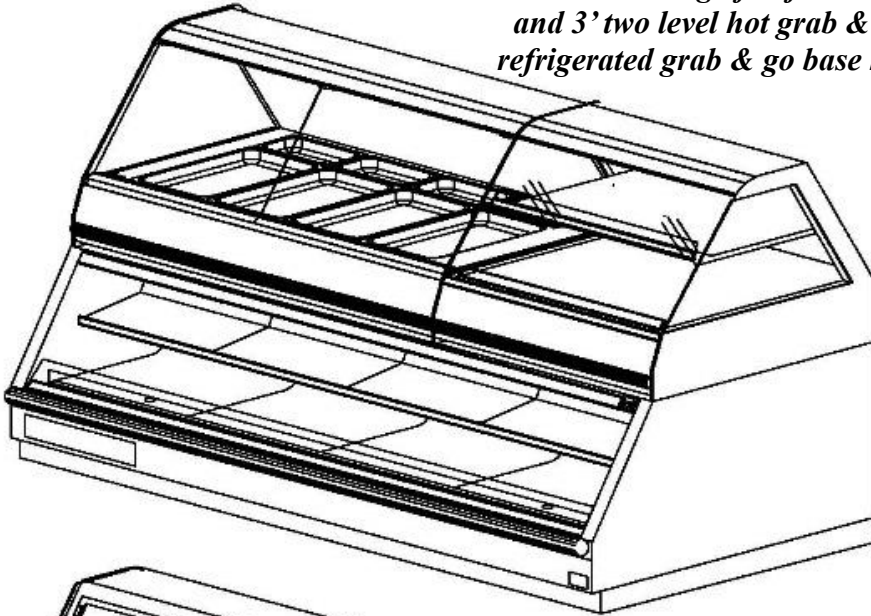

*8' case consisting of 4' three well hot service  
case and 4' one level hot grab & go on top and  
5' two level refrigerated grab & go base module  
and 3' two level hot grab & go base module*

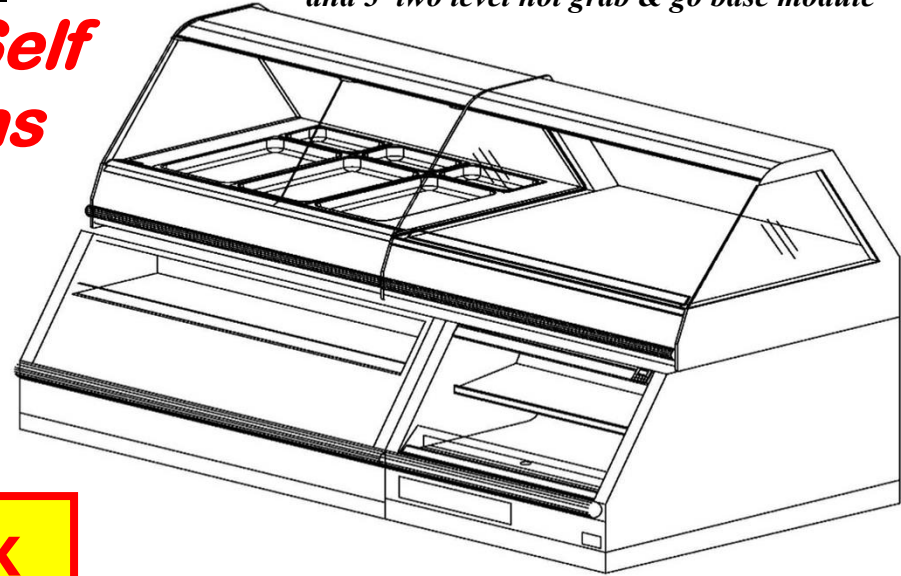

## **SHFBBK Series**

*Available in lengths  
from 4' to 16'*

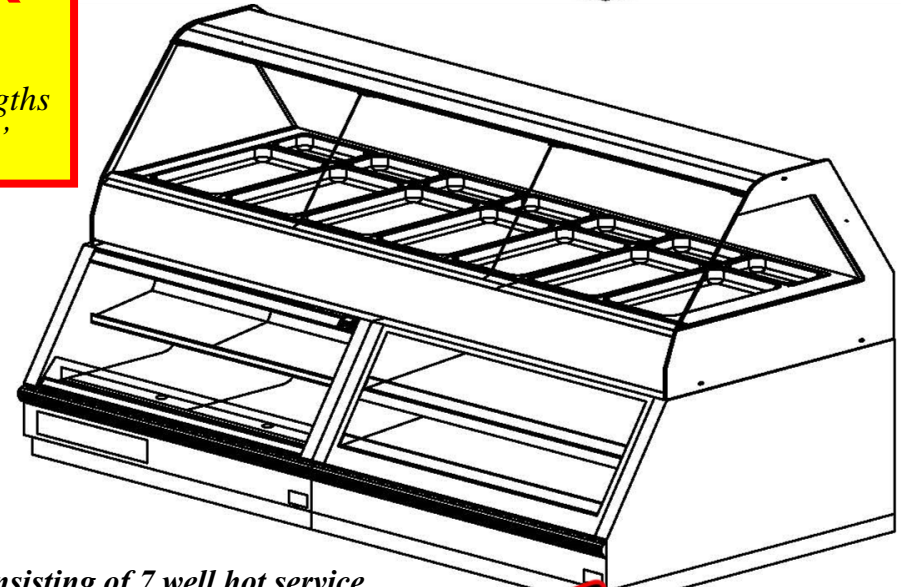

*8' case consisting of 7 well hot service  
case and 4' two level hot grab & go  
base module and 4' two level  
refrigerated grab & go base module*

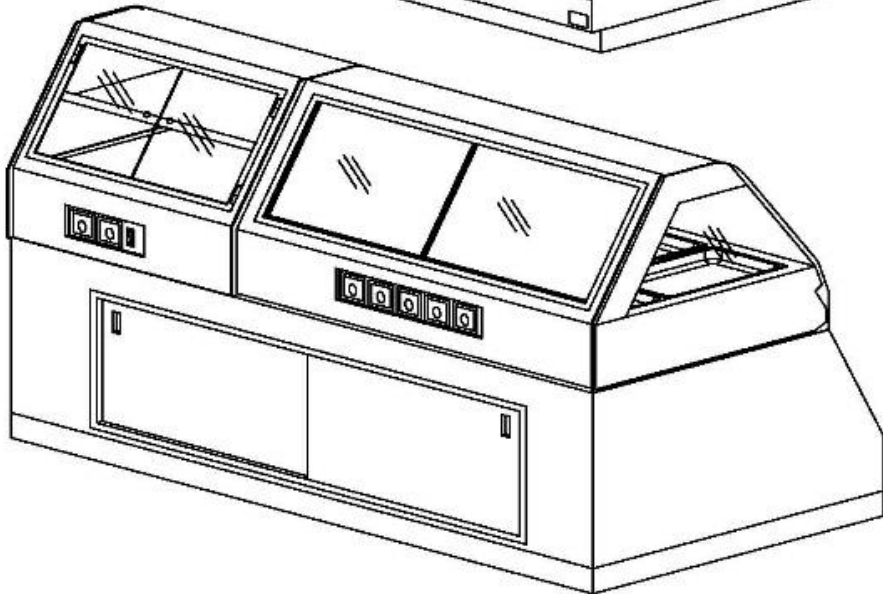

**Celebrating 70  
Years in 2017!**



**Atlantic Food Bars**  
Hot Food Merchandising  
Equipment Specialists

888-MEAL-SOLUTIONS (888-632-5765)  
[www.atlanticfoodbars.com](http://www.atlanticfoodbars.com)

# The Industry's Most Flexible Merchandising & Storage System

**1,000's of Hot / Cold / Dry Full and Self  
Service Mix & Match Configurations**

*10' case consisting of 8' seven well hot service case  
and 2' two level hot grab & go on top and  
base module with dry rear base storage*

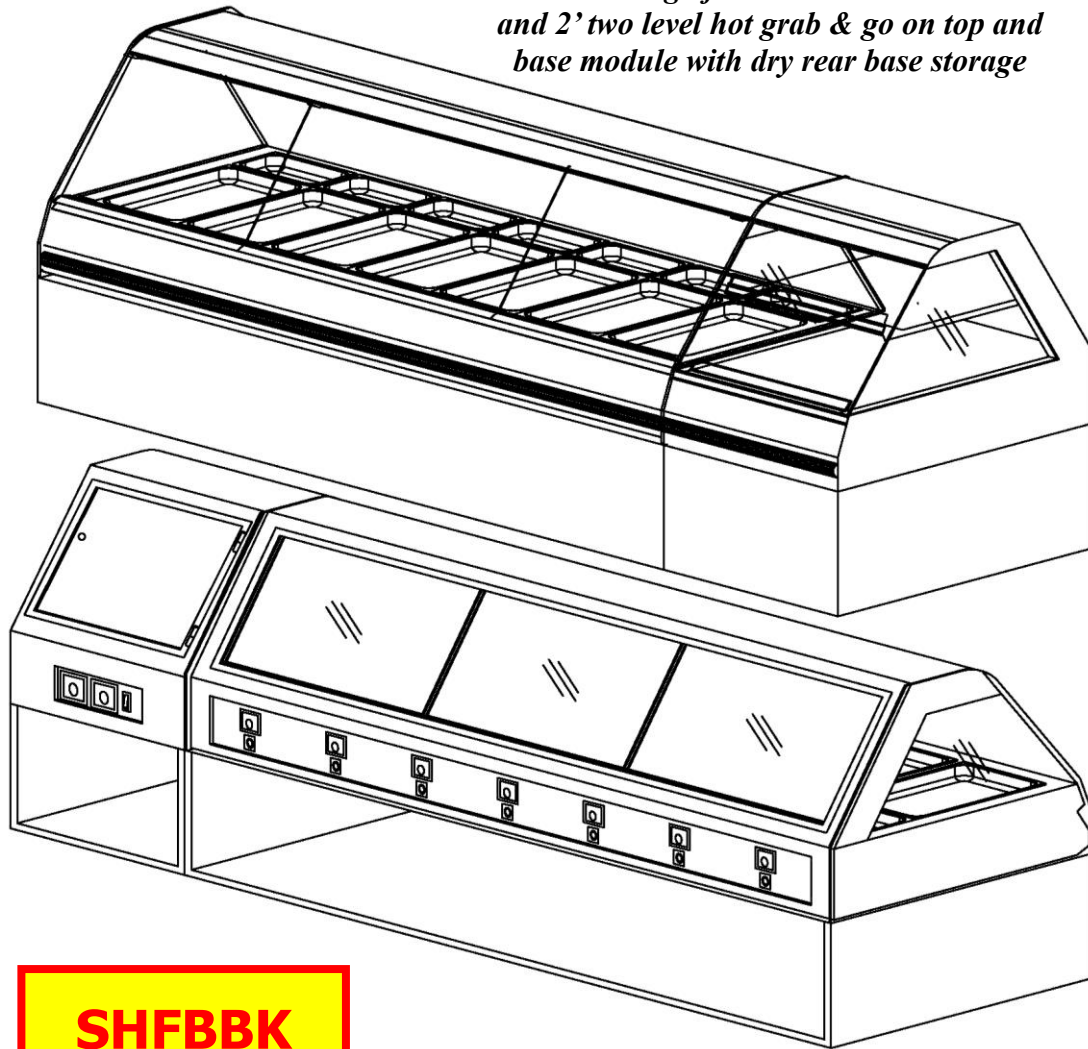

*8' seven well full service case with dry  
merchandising base module and  
dry rear base storage with two  
**HHC Hot Food Pan Holding Cabinets**  
(scroll down for more)*

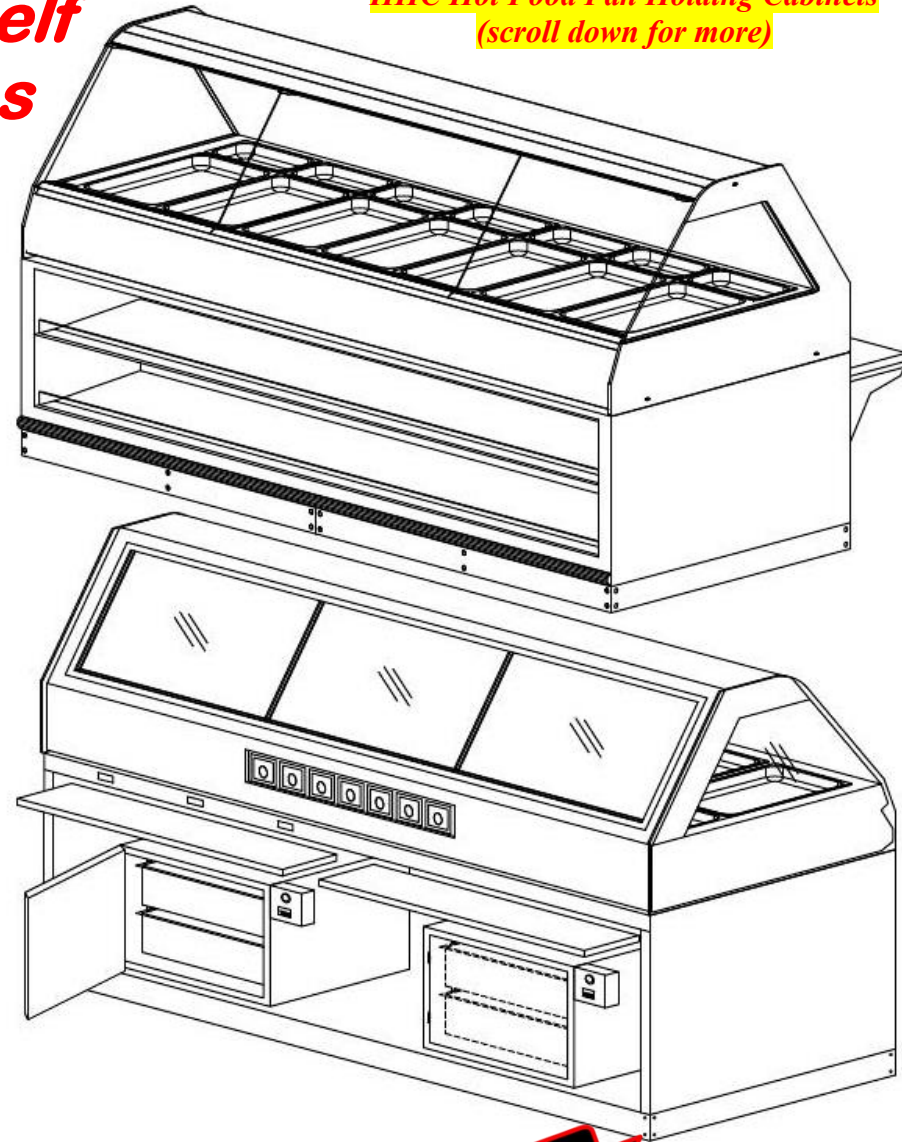

**SHFBBK  
Series**

*Available in lengths  
from 4' to 16'*

**Celebrating 70  
Years in 2017!**



**Atlantic Food Bars**  
Hot Food Merchandising  
Equipment Specialists

888-MEAL-SOLUTIONS (888-632-5765)  
[www.atlanticfoodbars.com](http://www.atlanticfoodbars.com)

# ***Hot Food Pan Holding Cabinets*** ***for use in rear base storage of*** ***Full Service Hot Food Merchandiser***

- *All stainless steel construction*
- *Fully insulated for energy efficiency*
- *Removable pan racks for ease of cleaning*
- *Self-closing gasketed door*
- *120V Plug & Play*



**HHC  
Series**



**HOT**



**Atlantic Food Bars**  
**Hot Food Merchandising**  
**Equipment Specialists**

888-MEAL-SOLUTIONS (888-632-5765)

[www.atlanticfoodbars.com](http://www.atlanticfoodbars.com)

# Hot Food Pan Holding Cabinets

## for use in rear base storage of Full Service Hot Food Merchandiser

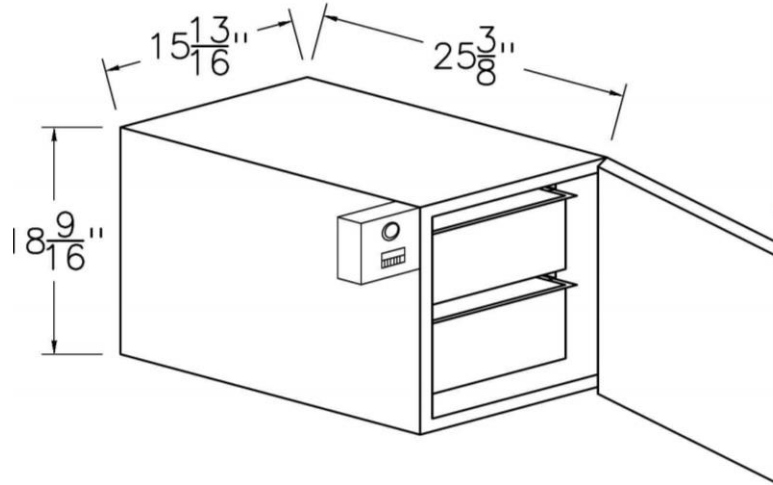
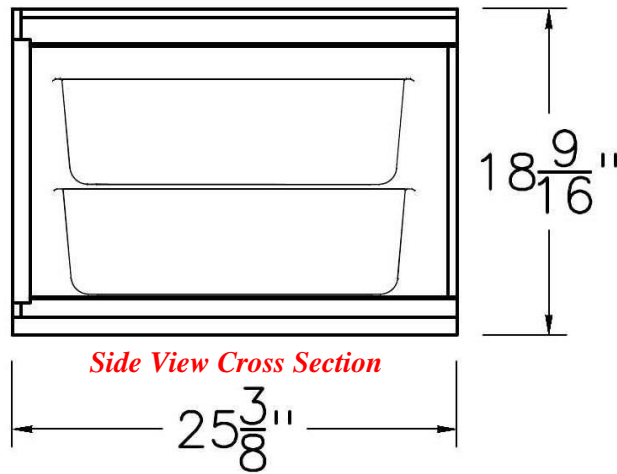
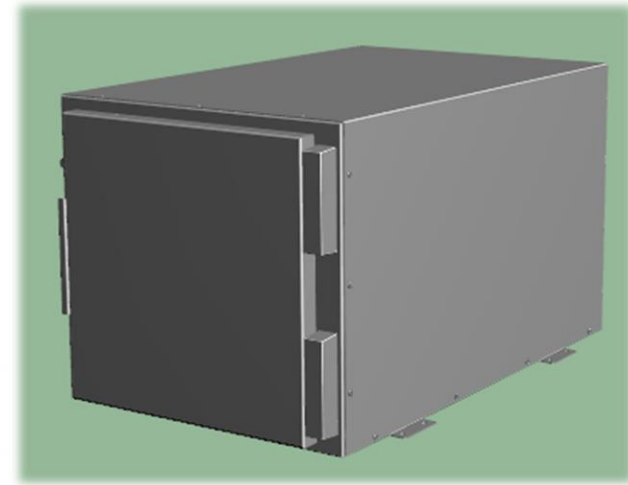

**HHC Series**

- All stainless steel construction
- Fully insulated for energy efficiency
- Removable pan racks for ease of cleaning
- Self-closing gasketed door
- 120V Plug & Play

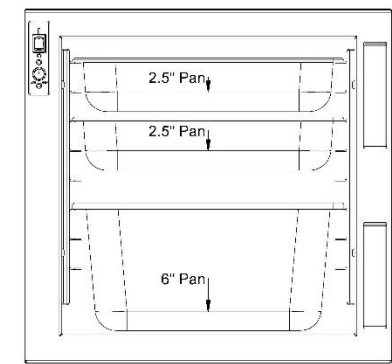
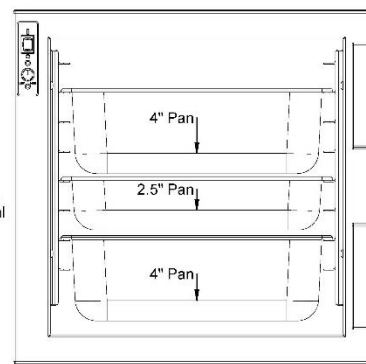
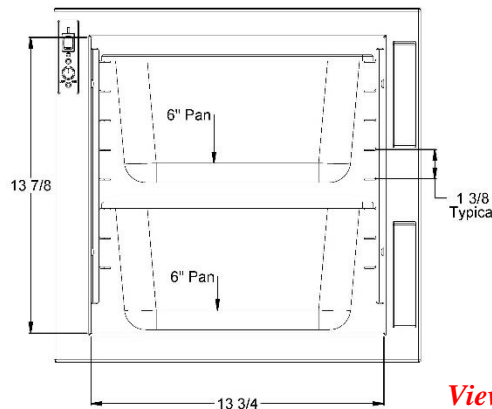

Views and pan capacity inside cabinet door

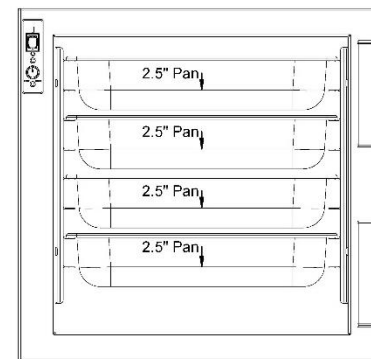
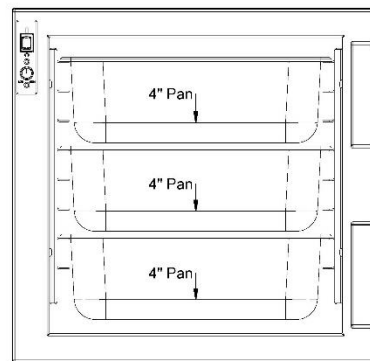

Celebrating 70 Years in 2017!

**HOT**

**Atlantic Food Bars**  
Hot Food Merchandising  
Equipment Specialists

888-MEAL-SOLUTIONS (888-632-5765)  
www.atlanticfoodbars.com